

RESOLUTION 26-09
A RESOLUTION APPROVING THE CONSENT AGENDA FOR
THE MEETING ON APRIL 16, 2026

Resolution by Mayor Pro Tem Kalman; seconded by Council Member Elsen

BE IT RESOLVED; the City Council of Keego Harbor accepts and authorizes the payment of bills for March 2026; and

BE IT RESOLVED; the City Council of Keego Harbor accepts the Revenue and Expenditure Report; and

BE IT RESOLVED; the City Council of Keego Harbor approves the following meeting minutes from:

- March 17, 2026, Study Session Meeting Minutes
- March 19, 2026, City Council Meeting Minutes
- March 19, 2026, Closed Session Meeting Minutes

BE IT RESOLVED; the City Council of Keego Harbor approves the following miscellaneous items:

- Resolution 26-10 West Nile Virus Prevention Reimbursement Program
- Orchard Lake Fine Art Show Banner
- TIFA Expenditure-Canal Fountains
- Council Member Liaison Appointment

Roll Call Vote:

- Mayor Ross
- Mayor Pro Tem Kalman
- Council Member Fletcher
- Council Member Elsen
- Council Member Streng

Mayor Ross declared this resolution to be adopted on April 16, 2026.

Tammy Neeb
City of Keego Harbor, City Clerk

Check Date	Bank	Check	Vendor	Vendor Name	Description	Amount
------------	------	-------	--------	-------------	-------------	--------

Bank APCHS ACCOUNTS PAYABLE

03/04/2026	APCHS	65464	HSA PD	HEALTH EQUITY	ROB ALONZI	6,750.00
03/04/2026	APCHS	65465	MISC	ROBERT ALONZI	ROBERT ALONZI	5,000.00

APCHS TOTALS:

Total of 2 Checks:						11,750.00
Less 0 Void Checks:						0.00
Total of 2 Disbursements:						11,750.00

Check Date	Bank	Check	Vendor	Vendor Name	Description	Amount
Bank APCHS ACCOUNTS PAYABLE						
03/10/2026	APCHS	65466	AT & T	AT & T	FEB-MARCH PHONE & INTERNET	235.56
03/10/2026	APCHS	65467	MISC	AXON ENTERPRISE	3RD INSTALLMENT FOR FLEET CAMERAS	6,972.96
03/10/2026	APCHS	65468	CARDMEMBER	CHASE CARD SERVICES	ADMIN & PD SUPPLIES, EGG HUNT EVENT	1,333.02
03/10/2026	APCHS	65469	COMCAST	COMCAST	MARCH DPW INTERNET	127.90
03/10/2026	APCHS	65470	CONSUMERS	CONSUMERS ENERGY	FEBRUARY CITY HALL UTILITIES	580.01
03/10/2026	APCHS	65471	CONSUMERS	CONSUMERS ENERGY	FEBRUARY DPW UTILITIES	919.89
03/10/2026	APCHS	65472	CORELOGIC	CORELOGIC REAL ESTATE TAX SERVICE	36-18-02-477-015 WINTER & SUMMER TAX REF	2,832.20
03/10/2026	APCHS	65473	HILLS, DAV	DAVE HILLS	FEBRUARY INSPECTIONS	2,025.00
03/10/2026	APCHS	65474	MISC	DMYTRO GORODETSKY	PERSONAL PROPERTY CLAIM	2,327.00
03/10/2026	APCHS	65475	MISC	FLEIS & VANDENBRINK	JANUARY TIFA ASSISTANCE	166.00
03/10/2026	APCHS	65476	FORD PRO	FORD PRO	FEBRUARY PD TELEMATICS	60.00
03/10/2026	APCHS	65477	J&J TOWING	J & J AUTO REPAIR	19-4 OIL CHANGE	96.95
03/10/2026	APCHS	65478	BORYCZ	KEN BORYCZ	FEBRUARY INSPECTIONS	100.00
03/10/2026	APCHS	65479	KMH	KMH CLEANING SERVICES	FEBRUARY CITY HALL CLEANING SERVICE	540.00
03/10/2026	APCHS	65480	MAMMOTH	MAMMOTH DOOR LLC	DPW DOOR REPAIR	200.00
03/10/2026	APCHS	65481	MCKENNA	MCKENNA	JANUARY SERVICES AND ARCH REVIEW	6,725.00
03/10/2026	APCHS	65482	MILLENNIUM	MILLENNIUM BUSINESS SYSTEMS	MARCH COPIER SERVICE	116.56
03/10/2026	APCHS	65483	NERDS	NERDS XPRESS	MARCH SERVICES	1,508.49
03/10/2026	APCHS	65484	OC TREAS	OAKLAND COUNTY TREASURER	TIFA BONDS -MCL 211.43 (2)	14.75
03/10/2026	APCHS	65485	PSI	PRINTING SYSTEMS INC	ELECTION AV OUTER ENVELOPES	216.29
03/10/2026	APCHS	65486	PSI	PRINTING SYSTEMS INC	ELECTIONS VOTER CARDS & SECRECY ENVELOPE	131.07
03/10/2026	APCHS	65487	PRIORITY	PRIORITY WASTE	MARCH CURBSIDE COLLECTION	20,112.30
03/10/2026	APCHS	65488	RAYMER, PA	PAUL RAYMER	FEBRUARY INSPECTIONS	50.00
03/10/2026	APCHS	65489	WATERFORD	WATERFORD TOWNSHIP	MARCH ASSESSMENTS	3,437.50
03/10/2026	APCHS	65490	WEX	WEX BANK	FEBRUARY PD & DPW FUEL	1,001.77
03/10/2026	APCHS	65491	WRC	WRC	CITY HALL QUARTERLY WATER BILLING	424.18
03/10/2026	APCHS	65492	WRC	WRC	DPW QUARTERLY WATER BILLING	218.24

APCHS TOTALS:

Total of 27 Checks:

52,472.64

Less 0 Void Checks:

0.00

Total of 27 Disbursements:

52,472.64

User: Goodall

CHECK NUMBERS 65493 - 65528

DB: Keego Harbor

Check Date	Bank	Check	Vendor	Vendor Name	Description	Amount
Bank APCHS ACCOUNTS PAYABLE						
03/25/2026	APCHS	65493	BCBSM	BLUE CROSS BLUE SHIELD OF MICHIGAN	APRIL MEDICAL COVERAGE	4,010.65
03/25/2026	APCHS	65494	COPS HEALT	COPS HEALTH TRUST	DENTAL COVERAGE	396.85
03/25/2026	APCHS	65495	DTE ENERGY	DTE ENERGY	FEB-MARCH FRAN LEAF PARK	17.41
03/25/2026	APCHS	65496	DTE ENERGY	DTE ENERGY	FEB-MARCH VETERANS MEMORIAL	25.66
03/25/2026	APCHS	65497	DTE ENERGY	DTE ENERGY	FEB-MARCH 1768 CLF RD STREET CONTROLLER	75.27
03/25/2026	APCHS	65498	DTE ENERGY	DTE ENERGY	FEB-MARCH 1765 CLF RD STREET CONTROLLER	79.52
03/25/2026	APCHS	65499	DTE ENERGY	DTE ENERGY	FEB-MARCH SUNSET PARK	17.41
03/25/2026	APCHS	65500	DTE ENERGY	DTE ENERGY	FEB-MARCH ROSE SORTOR PARK	22.61
03/25/2026	APCHS	65501	DTE ENERGY	DTE ENERGY	FEB-MARCH CITY HALL	777.69
03/25/2026	APCHS	65502	DTE ENERGY	DTE ENERGY	FEB-MARCH DPW	917.60
03/25/2026	APCHS	65503	EDISON	DTE ENERGY	JAN-FEB STREETLIGHTS	5,903.62
03/25/2026	APCHS	65504	MISC	FLEIS & VANDENBRINK	FEBRUARY PROFESSIONAL SERVICES	954.50
03/25/2026	APCHS	65505	GMH	GIRAMARCO,MULLINS & HORTON, P.C.	FEBRUARY PROFESSIONAL SERVICES	2,500.00
03/25/2026	APCHS	65506	GMH	GIRAMARCO,MULLINS & HORTON, P.C.	FEBRUARY LABOR & EMPLOYMENT	4,290.00
03/25/2026	APCHS	65507	GMH	GIRAMARCO,MULLINS & HORTON, P.C.	FEBRUARY PROSECUTIONS	2,940.00
03/25/2026	APCHS	65508	GMH	GIRAMARCO,MULLINS & HORTON, P.C.	FEBRUARY REAL ESTATE MATTERS	210.00
03/25/2026	APCHS	65509	HRC	HUBBELL, ROTH, & CLARK INC	FEBRUARY WILLOW BEACH REHAB	26,544.31
03/25/2026	APCHS	65510	HRC	HUBBELL, ROTH, & CLARK INC	GLWA WATER STUDY PLAN REVIEW	216.63
03/25/2026	APCHS	65511	HRC	HUBBELL, ROTH, & CLARK INC	LOCAL CVT INFRASTRUCTURE PLANNING WATER	1,416.88
03/25/2026	APCHS	65512	HRC	HUBBELL, ROTH, & CLARK INC	LOCAL CVT INFRASTRUCTURE PLANNING WATER	3,198.58
03/25/2026	APCHS	65513	HRC	HUBBELL, ROTH, & CLARK INC	LOCAL CVT INFRASTRUCTURE PLANNING SANITA	91.35
03/25/2026	APCHS	65514	HRC	HUBBELL, ROTH, & CLARK INC	FEBRUARY MS4 PERMIT ASSISTANCE	538.97
03/25/2026	APCHS	65515	MCKENNA	MCKENNA	FEBRUARY PROFESSIONAL SERVICES	6,257.00
03/25/2026	APCHS	65516	MML WC	MML WORKERS' COMP FUND	2024-2025 PAYROLL AUDIT	1,228.00
03/25/2026	APCHS	65517	NEEB	NEEB, TAMMY	OFFICE FURNITURE MILEAGE REIMBURSEMENT	24.65
03/25/2026	APCHS	65518	NERDS	NERDS XPRESS	DIGITAL SIGNAGE	953.89
03/25/2026	APCHS	65519	OC TREAS	OAKLAND COUNTY TREASURER	NOVEMBER, DECEMBER & JANUARY TRAILER TAX	327.50
03/25/2026	APCHS	65520	PETTY CASH	PETTY CASH	WATER, BATTERIES, NAME PLATES, CONFERENC	111.98
03/25/2026	APCHS	65521	PSI	PRINTING SYSTEMS INC	AV BALLOT RETURN ENVELOPES	202.64
03/25/2026	APCHS	65522	RCOC	ROAD COMMISSION FOR OAKLAND COUNTY	OCTOBER 2025 SIGNAL MAINTENENCE	795.23
03/25/2026	APCHS	65523	RCOC	ROAD COMMISSION FOR OAKLAND COUNTY	MAY 2025 SIGNAL MAINTENENCE	27.51
03/25/2026	APCHS	65524	RCOC	ROAD COMMISSION FOR OAKLAND COUNTY	JANUARY 2026 SIGNAL MAINTENENCE	27.51
03/25/2026	APCHS	65525	MISC	STACY GOODALL	CLERK'S CONFERENCE MILEAGE REIMBURSEMENT	182.70
03/25/2026	APCHS	65526	STANDARD	STANDARD INSURANCE COMPANY	APRIL LIFE INSURANCE	527.60
03/25/2026	APCHS	65527	TRI CITY	TRI-CITY FIRE DEPARTMENT	TRI-CITY FIRE SERVICES 4TH PAYMENT	95,193.00
03/25/2026	APCHS	65528	VERIZON	VERIZON	FEBRUARY PHONE CHARGES	433.99

APCHS TOTALS:

Total of 36 Checks:	161,438.71
Less 0 Void Checks:	0.00
Total of 36 Disbursements:	161,438.71

REVENUE AND ESPENDITURE REPORT FOR CITY OF KEEGO HARBOR

PERIOD ENDING 3.31.26

		2025-2026 Budget	YTD Balance as of 3/2026	Activity for Month	Available Balance	% Budget Used
TOTAL Fund 101	General Fund					
	Revenue	\$ 2,584,695.00	\$ 2,253,702.38	\$ 12,954.15	\$ 330,992.62	87.19
	Expenditure	\$ 2,995,032.00	\$ 2,170,966.86	\$ 206,714.82	\$ 824,065.14	72.49
TOTAL Fund 202	Major Street Fund					
	Revenue	\$ 226,692.00	\$ 148,342.81	\$ -	\$ 78,349.19	65.44
	Expenditure	\$ 339,532.00	\$ 208,624.29	\$ 1,922.88	\$ 130,907.71	61.44
TOTAL Fund 203	Local Street Fund					
	Revenue	\$ 1,010,718.00	\$ 245,217.12	\$ -	\$ 765,500.88	24.26
	Expenditure	\$ 1,099,424.00	\$ 281,070.92	\$ 31,250.43	\$ 818,353.08	25.57
TOTAL Fund 207	Police Fund					
	Revenue	\$ 1,301,800.00	\$ 1,136,547.29	\$ 65.01	\$ 165,252.71	87.31
	Expenditure	\$ 1,301,800.00	\$ 1,020,055.51	\$ 108,082.47	\$ 281,744.49	78.36
TOTAL Fund 247	TIFA					
	Revenue	\$ 340,200.00	\$ 320,743.52	\$ -	\$ 19,456.48	94.28
	Expenditure	\$ 363,518.00	\$ 126,699.07	\$ 6,614.46	\$ 236,818.93	34.85
TOTAL Fund 271	Library					
	Revenue	\$ 37,100.00	\$ 36,012.05	\$ -	\$ 1,087.95	97.07
	Expenditure	\$ 37,100.00	\$ 38,301.64	\$ -	\$ (1,201.64)	103.24
TOTAL Fund 401	Capital Improvements					
	Revenue	\$ 236,600.00	\$ 171,680.00	\$ -	\$ 64,920.00	72.56
	Expenditure	\$ 236,600.00	\$ 158,575.34	\$ 6,972.96	\$ 78,024.66	67.02
TOTAL Fund 592	Water & Sewer Fund					
	Revenue	\$ 241,900.00	\$ 53,083.69	\$ 3,703.00	\$ 188,816.31	21.94
	Expenditure	\$ 283,000.00	\$ 24,949.00	\$ 4,615.46	\$ 258,051.00	8.82
TOTAL	Revenue	\$ 5,395,431.00	\$ 4,357,121.37	\$ 509,350.29	\$ 1,038,309.63	80.76
	Expenditure	\$ 5,678,558.00	\$ 3,663,069.15	\$ 684,628.64	\$ 2,015,488.85	64.51

GL NUMBER	DESCRIPTION	YTD BALANCE	2025-26	YTD BALANCE	ACTIVITY FOR	AVAILABLE	% BGDG
		03/31/2025	AMENDED BUDGET	03/31/2026	MONTH 03/31/26	BALANCE	USED
Fund 101 - GENERAL FUND							
Revenues							
Dept 000 - UNCLASSIFIED							
101-000-402.000	CURRENT TAXES	1,286,236.20	1,414,100.00	1,338,183.80	0.00	75,916.20	94.63
101-000-402.100	PUBLIC ACT 359 OF 1925	47,857.69	50,000.00	48,359.10	0.00	1,640.90	96.72
101-000-403.000	PRE DENIAL INT & PENALTY FR CO	161.11	300.00	122.47	0.00	177.53	40.82
101-000-404.000	NON CURRENT PROPERTY TAXES	2,540.21	2,350.00	0.00	0.00	2,350.00	0.00
101-000-434.000	TRAILER TAX-CITY PORTION	236.50	400.00	237.50	65.50	162.50	59.38
101-000-445.000	PENALTIES AND INTEREST ON TAXES	13,557.92	24,000.00	5,200.12	0.00	18,799.88	21.67
101-000-446.000	PROPERTY TRANSFER PENALTY	600.00	5,000.00	1,000.00	0.00	4,000.00	20.00
101-000-447.000	PROPERTY TAX ADMIN FEE	63,284.64	65,400.00	65,138.77	0.00	261.23	99.60
101-000-448.000	REFUSE COLLECTION	210,383.32	238,082.00	244,193.81	0.00	(6,111.81)	102.57
101-000-448.100	REFUSE COLLECTION ADMIN FEE	38,300.00	38,320.00	19,160.00	0.00	19,160.00	50.00
101-000-448.101	RECYCLING	4,605.24	5,000.00	4,556.29	0.00	443.71	91.13
101-000-449.000	WEED CUTTING	1,200.00	1,200.00	1,277.90	0.00	(77.90)	106.49
101-000-451.100	CONTRACTOR REGISTRATION FEE	680.00	1,500.00	715.00	60.00	785.00	47.67
101-000-451.101	BUILDING PERMIT FEE	31,386.37	35,000.00	35,126.65	3,209.89	(126.65)	100.36
101-000-451.102	MECHANICAL PERMIT FEE	5,595.00	6,300.00	5,700.00	435.00	600.00	90.48
101-000-451.103	ELECTRICAL PERMIT FEE	6,750.00	7,000.00	4,778.00	917.00	2,222.00	68.26
101-000-451.104	PLUMBING PERMIT FEE	4,230.00	5,200.00	4,250.00	685.00	950.00	81.73
101-000-451.106	WATERLINE/SEWER TRENCH FEE	0.00	1,000.00	0.00	0.00	1,000.00	0.00
101-000-451.107	REINSPECTION FEE	570.00	3,500.00	5,000.00	0.00	(1,500.00)	142.86
101-000-451.108	DEMOLITION PERMIT FEE	0.00	600.00	840.00	0.00	(240.00)	140.00
101-000-451.109	FERTILIZER PERMIT FEE	0.00	100.00	0.00	0.00	100.00	0.00
101-000-452.000	RENTAL REGISTRATION FEE	12,650.00	20,000.00	5,825.00	150.00	14,175.00	29.13
101-000-452.001	RENTAL REINSPECTION FEE	1,495.00	2,000.00	320.00	65.00	1,680.00	16.00
101-000-453.000	BUSINESS LICENSE	5,880.00	8,000.00	5,305.00	560.00	2,695.00	66.31
101-000-460.000	CABLE FRANCHISE FEE	31,037.16	37,000.00	19,665.16	0.00	17,334.84	53.15
101-000-477.000	PET LICENSE-CITY PORTION	30.00	100.00	22.00	12.00	78.00	22.00
101-000-528.000	FEDERAL GRANTS	20,000.00	0.00	0.00	0.00	0.00	0.00
101-000-529.000	CDBG REVENUE	0.00	10,175.00	0.00	0.00	10,175.00	0.00
101-000-541.000	SMART	556.00	2,500.00	0.00	0.00	2,500.00	0.00
101-000-573.000	LOCAL COMMUNITY STABILIZATION S	6,645.68	6,600.00	11,447.64	0.00	(4,847.64)	173.45
101-000-574.000	STATE REVENUE SHARING	224,102.00	337,010.00	227,301.00	0.00	109,709.00	67.45
101-000-576.000	STATE-ELECTION REIMBURSEMENT	3,481.42	2,500.00	135.79	0.00	2,364.21	5.43
101-000-581.000	COUNTY REVENUE SHARING	451.60	1,500.00	246.83	0.00	1,253.17	16.46
101-000-607.000	CHARGES FOR SERVICES	343.97	400.00	302.84	0.00	97.16	75.71
101-000-610.000	BUILDING DEPT REVIEW FEE	1,000.00	100.00	15.00	0.00	85.00	15.00
101-000-612.000	RECYCLING BINS	60.00	100.00	12.00	0.00	88.00	12.00
101-000-613.000	LAND DIVISION/CONSOLIDATION	0.00	500.00	0.00	0.00	500.00	0.00
101-000-614.000	PLANNER REVIEW FEES (NON-REFUND)	4,685.00	7,000.00	10,600.00	125.00	(3,600.00)	151.43
101-000-615.000	ZBA APPEAL FEE	0.00	2,500.00	2,200.00	0.00	300.00	88.00
101-000-625.000	NSF FEES	0.00	100.00	0.00	0.00	100.00	0.00
101-000-627.202	CONTRIBUTION/ADMIN FROM 202 MAJ	16,700.00	21,700.00	0.00	0.00	21,700.00	0.00
101-000-627.203	ADMIN CHARGES FROM 203 LOCAL S	7,100.00	9,300.00	0.00	0.00	9,300.00	0.00
101-000-627.247	ADMIN CHARGES FROM TIFA FUND	48,195.00	50,408.00	50,408.00	0.00	0.00	100.00
101-000-643.900	BOAT KEY-PARKS PORTION	120.00	200.00	80.00	0.00	120.00	40.00
101-000-656.000	DISTRICT COURT FINES	0.00	1,500.00	0.00	0.00	1,500.00	0.00
101-000-665.000	INTEREST	50,857.66	100,000.00	86,439.98	1,888.34	13,560.02	86.44
101-000-668.000	EQUIPMENT AND VEHICLE RENTAL	18,439.27	37,000.00	29,625.44	3,894.42	7,374.56	80.07
101-000-674.000	DONATIONS	0.00	250.00	0.00	0.00	250.00	0.00
101-000-674.012	PARKS & REC COMMUNITY EVENTS	2,476.00	1,000.00	122.00	0.00	878.00	12.20
101-000-674.013	DONATIONS GARDEN CLUB	95.00	300.00	85.00	60.00	215.00	28.33
101-000-674.014	DONATIONS BLOCK PARTY	786.00	600.00	0.00	0.00	600.00	0.00
101-000-675.000	COST REC- MISC/REIMBURSEMENT	8,452.30	10,000.00	14,188.29	827.00	(4,188.29)	141.88
101-000-675.003	COST RECOVERY - MMRMA	9,943.00	10,000.00	5,516.00	0.00	4,484.00	55.16

REVENUE AND EXPENDITURE REPORT FOR CITY OF KEEGO HARBOR
PERIOD ENDING 03/31/2026
% Fiscal Year Completed: 75.07

GL NUMBER	DESCRIPTION	YTD BALANCE 03/31/2025	2025-26 AMENDED BUDGET	YTD BALANCE 03/31/2026	ACTIVITY FOR MONTH 03/31/26	AVAILABLE BALANCE	% BDGT USED
Fund 101 - GENERAL FUND							
Revenues							
Total Dept 000 - UNCLASSIFIED		2,193,756.26	2,584,695.00	2,253,702.38	12,954.15	330,992.62	87.19
TOTAL REVENUES		2,193,756.26	2,584,695.00	2,253,702.38	12,954.15	330,992.62	87.19
Expenditures							
Dept 101 - CITY COUNCIL							
101-101-801.000	COUNCIL PAY	393.75	600.00	393.75	0.00	206.25	65.63
101-101-955.000	PROF DEVELOPMENT/TRAINING	0.00	2,000.00	0.00	0.00	2,000.00	0.00
Total Dept 101 - CITY COUNCIL		393.75	2,600.00	393.75	0.00	2,206.25	15.14
Dept 172 - CITY MANAGER							
101-172-702.000	WAGES-FULL TIME	70,884.63	102,000.00	76,853.80	11,528.07	25,146.20	75.35
101-172-711.000	FICA	5,638.86	7,803.00	6,107.00	916.05	1,696.00	78.26
101-172-711.005	RETIREMENT PLAN	7,184.67	10,200.00	6,532.59	0.00	3,667.41	64.05
101-172-711.006	LIFE INSURANCE	590.04	830.00	655.60	65.56	174.40	78.99
101-172-711.014	HEALTH INSURANCE OPT OUT	3,653.70	5,000.00	3,846.00	576.90	1,154.00	76.92
101-172-850.002	24/7 COMMUNICATION	1,500.03	2,000.00	1,500.02	166.67	499.98	75.00
101-172-955.000	PROF DEVELOPMENT/TRAINING	820.00	2,500.00	800.00	0.00	1,700.00	32.00
101-172-955.001	DUES & MEMBERSHIP	0.00	500.00	0.00	0.00	500.00	0.00
Total Dept 172 - CITY MANAGER		90,271.93	130,833.00	96,295.01	13,253.25	34,537.99	73.60
Dept 215 - CITY CLERK							
101-215-702.000	WAGES-FULL TIME	30,809.26	44,600.00	34,326.30	5,610.41	10,273.70	76.96
101-215-711.000	FICA	2,636.41	3,400.00	2,920.16	473.33	479.84	85.89
101-215-711.006	LIFE INSURANCE	371.16	500.00	382.00	38.20	118.00	76.40
101-215-711.014	HEALTH INSURANCE OPT OUT	3,653.89	5,000.00	3,846.20	576.93	1,153.80	76.92
101-215-862.000	MILEAGE REIMBURSEMENT	0.00	200.00	0.00	0.00	200.00	0.00
101-215-955.000	PROF DEVELOPMENT/TRAINING	315.00	2,000.00	120.00	0.00	1,880.00	6.00
101-215-955.001	DUES & MEMBERSHIP	0.00	500.00	50.00	0.00	450.00	10.00
Total Dept 215 - CITY CLERK		37,785.72	56,200.00	41,644.66	6,698.87	14,555.34	74.10
Dept 228 - INFORMATION TECHNOLOGY							
101-228-803.000	COMPUTER SERVICES	11,044.74	17,000.00	16,443.55	1,508.49	556.45	96.73
101-228-805.000	COMPUTER SUPPORT-BSA	0.00	3,000.00	1,116.12	589.12	1,883.88	37.20
101-228-805.001	COMPUTER SUPPORT-NON BSA	0.00	4,500.00	1,722.00	0.00	2,778.00	38.27
Total Dept 228 - INFORMATION TECHNOLOGY		11,044.74	24,500.00	19,281.67	2,097.61	5,218.33	78.70
Dept 253 - FINANCE/TREASURER							
101-253-702.000	WAGES-FULL TIME	32,098.91	24,400.00	18,349.57	2,905.50	6,050.43	75.20
101-253-711.000	FICA	2,162.16	1,845.00	1,224.32	195.36	620.68	66.36
101-253-711.004	HEALTH INSURANCE	13,267.64	13,200.00	14,804.45	910.73	(1,604.45)	112.15
101-253-711.006	LIFE INSURANCE	439.38	600.00	488.20	48.82	111.80	81.37
101-253-862.000	MILEAGE REIMBURSEMENT	0.00	200.00	191.80	0.00	8.20	95.90
101-253-955.000	PROF DEVELOPMENT/TRAINING	0.00	2,000.00	1,026.00	0.00	974.00	51.30
101-253-955.001	DUES & MEMBERSHIP	119.00	500.00	133.75	14.75	366.25	26.75

REVENUE AND EXPENDITURE REPORT FOR CITY OF KEEGO HARBOR
PERIOD ENDING 03/31/2026
% Fiscal Year Completed: 75.07

GL NUMBER	DESCRIPTION	YTD BALANCE 03/31/2025	2025-26 AMENDED BUDGET	YTD BALANCE 03/31/2026	ACTIVITY FOR MONTH 03/31/26	AVAILABLE BALANCE	% BDGT USED
Fund 101 - GENERAL FUND							
Expenditures							
Total Dept 253 - FINANCE/TREASURER		48,087.09	42,745.00	36,218.09	4,075.16	6,526.91	84.73
Dept 257 - ASSESSING							
101-257-802.000	ASSESSING SERVICES	27,000.76	41,375.00	30,770.75	3,437.50	10,604.25	74.37
Total Dept 257 - ASSESSING		27,000.76	41,375.00	30,770.75	3,437.50	10,604.25	74.37
Dept 262 - ELECTIONS							
101-262-728.000	SUPPLIES	987.68	1,500.00	1,098.91	550.00	401.09	73.26
101-262-731.000	POSTAGE	500.00	600.00	0.00	0.00	600.00	0.00
101-262-800.000	SERVICES AND CHARGES	1,079.52	800.00	3,278.50	0.00	(2,478.50)	409.81
101-262-801.000	ELECTION WORKER PAY	1,485.00	800.00	753.00	0.00	47.00	94.13
101-262-862.000	MILEAGE REIMBURSEMENT	0.00	150.00	0.00	0.00	150.00	0.00
Total Dept 262 - ELECTIONS		4,052.20	3,850.00	5,130.41	550.00	(1,280.41)	133.26
Dept 265 - BUILDING & GROUNDS							
101-265-728.000	SUPPLIES	0.00	1,200.00	0.00	0.00	1,200.00	0.00
101-265-850.000	TELEPHONE	1,975.30	3,000.00	1,955.13	217.00	1,044.87	65.17
101-265-920.000	UTILITIES	10,487.66	13,500.00	11,137.29	2,152.34	2,362.71	82.50
101-265-930.000	MAINTENANCE AND REPAIRS	2,787.17	14,750.00	2,259.33	0.00	12,490.67	15.32
Total Dept 265 - BUILDING & GROUNDS		15,250.13	32,450.00	15,351.75	2,369.34	17,098.25	47.31
Dept 267 - GENERAL GOVERNMENT							
101-267-707.000	WAGES- PART TIME/SEASONAL	4,909.82	19,000.00	1,397.76	0.00	17,602.24	7.36
101-267-711.000	FICA	376.58	1,508.00	0.00	0.00	1,508.00	0.00
101-267-711.005	RETIREMENT - MERS DB	144,387.00	203,244.00	152,433.00	16,937.00	50,811.00	75.00
101-267-711.007	WORKERS COMP	305.91	2,000.00	79.83	79.83	1,920.17	3.99
101-267-711.008	UNEMPLOYMENT	10.12	500.00	19.14	0.00	480.86	3.83
101-267-711.015	RETIREMENT SUPPLEMENTAL	0.00	20,000.00	20,000.00	0.00	0.00	100.00
101-267-725.001	FUEL	0.00	200.00	0.00	0.00	200.00	0.00
101-267-728.000	SUPPLIES	5,863.17	7,300.00	4,087.59	542.53	3,212.41	55.99
101-267-731.000	POSTAGE	2,281.50	3,500.00	2,818.44	500.00	681.56	80.53
101-267-800.001	BANK SERVICE CHARGE	629.39	1,000.00	1,049.49	344.55	(49.49)	104.95
101-267-800.101	LEGAL FEES-GENERAL PERSONNEL	0.00	10,000.00	5,000.00	0.00	5,000.00	50.00
101-267-800.265	LEGAL FEES CITY ATTORNEY	60,019.00	75,000.00	38,971.80	7,420.00	36,028.20	51.96
101-267-802.000	PROFESSIONAL AND TECHNICAL SERV	92,290.23	120,000.00	130,882.36	14,465.84	(10,882.36)	109.07
101-267-802.203	STORMWATER	1,163.32	1,700.00	3,244.00	0.00	(1,544.00)	190.82
101-267-806.211	AUDIT SERVICES	0.00	16,500.00	14,350.00	0.00	2,150.00	86.97
101-267-827.000	INSURANCE-MMRMA	4,018.34	4,500.00	7,172.91	0.00	(2,672.91)	159.40
101-267-862.000	MILEAGE REIMBURSEMENT	0.00	520.00	225.55	207.35	294.45	43.38
101-267-900.000	PRINTING AND BINDING	2,764.28	3,200.00	1,666.11	0.00	1,533.89	52.07
101-267-901.000	PUBLICATION	1,537.75	2,500.00	1,950.20	0.00	549.80	78.01
101-267-944.001	COPIER & MAINTENANCE	1,097.22	1,700.00	1,043.40	116.56	656.60	61.38
101-267-955.000	PROF DEVELOPMENT/TRAINING	250.00	800.00	325.00	0.00	475.00	40.63
101-267-955.001	DUES & MEMBERSHIP	5,184.04	7,000.00	3,887.04	0.00	3,112.96	55.53
101-267-956.000	COSTS, FEES, AND CHARGES	12.72	500.00	1,508.08	0.00	(1,008.08)	301.62
Total Dept 267 - GENERAL GOVERNMENT		327,100.39	502,172.00	392,111.70	40,613.66	110,060.30	78.08

REVENUE AND EXPENDITURE REPORT FOR CITY OF KEEGO HARBOR
PERIOD ENDING 03/31/2026
% Fiscal Year Completed: 75.07

GL NUMBER	DESCRIPTION	YTD BALANCE 03/31/2025	2025-26 AMENDED BUDGET	YTD BALANCE 03/31/2026	ACTIVITY FOR MONTH 03/31/26	AVAILABLE BALANCE	% BDGT USED
Fund 101 - GENERAL FUND							
Expenditures							
Dept 336 - FIRE PROTECTION							
101-336-814.000	TRI CITY FIRE SERVICES	369,324.00	380,772.00	380,772.00	95,193.00	0.00	100.00
Total Dept 336 - FIRE PROTECTION		369,324.00	380,772.00	380,772.00	95,193.00	0.00	100.00
Dept 371 - BUILDING INSPECTION SERVICES							
101-371-707.000	WAGES- PART TIME	24,111.98	36,350.00	25,986.04	4,385.28	10,363.96	71.49
101-371-711.000	FICA	2,002.76	2,790.00	2,345.63	370.80	444.37	84.07
101-371-711.006	LIFE INSURANCE	138.64	500.00	405.60	40.56	94.40	81.12
101-371-711.014	HEALTH INSURANCE OPT OUT	1,230.72	4,000.00	3,076.80	461.52	923.20	76.92
101-371-802.101	BUILDING PERMIT INSPECTION	7,400.00	9,800.00	9,580.00	850.00	220.00	97.76
101-371-802.102	MECHANICAL PERMIT INSPECTION	2,350.00	5,500.00	2,000.00	100.00	3,500.00	36.36
101-371-802.103	ELECTRICAL PERMIT INSPECTION	3,362.00	4,500.00	1,600.00	50.00	2,900.00	35.56
101-371-802.104	PLUMBING PERMIT INSPECTION	1,150.00	1,500.00	1,050.00	0.00	450.00	70.00
101-371-802.105	RENTAL INSPECTION	11,150.00	15,000.00	3,600.00	400.00	11,400.00	24.00
101-371-802.106	BLDG INSPECTION SERVICES	2,950.00	4,000.00	9,700.00	775.00	(5,700.00)	242.50
Total Dept 371 - BUILDING INSPECTION SERVICES		55,846.10	83,940.00	59,344.07	7,433.16	24,595.93	70.70
Dept 441 - DEPT OF PUBLIC WORKS							
101-441-702.000	WAGES-FULL TIME	24,510.81	60,000.00	44,360.03	4,319.21	15,639.97	73.93
101-441-704.000	OVERTIME	1,809.76	3,000.00	168.75	0.00	2,831.25	5.63
101-441-708.000	UNIFORM ALLOWANCE	242.00	500.00	91.00	0.00	409.00	18.20
101-441-711.000	FICA	2,219.72	5,200.00	3,089.86	314.60	2,110.14	59.42
101-441-711.004	HEALTH INSURANCE	0.00	11,000.00	8,767.70	(3,638.43)	2,232.30	79.71
101-441-711.005	RETIREMENT PLAN	4,950.37	9,400.00	7,217.35	0.00	2,182.65	76.78
101-441-711.006	LIFE INSURANCE	441.36	1,000.00	917.11	(50.12)	82.89	91.71
101-441-711.007	WORKERS COMP	74.16	800.00	354.89	354.89	445.11	44.36
101-441-711.008	UNEMPLOYMENT	2.49	400.00	1.26	0.00	398.74	0.32
101-441-711.014	HEALTH INSURANCE OPT OUT	2,922.96	4,000.00	3,076.80	461.52	923.20	76.92
101-441-725.000	FUEL	1,569.61	3,000.00	2,806.30	100.14	193.70	93.54
101-441-728.000	SUPPLIES	985.50	10,000.00	1,357.84	67.28	8,642.16	13.58
101-441-802.000	PROFESSIONAL AND TECHNICAL SERV:	0.00	1,000.00	200.00	200.00	800.00	20.00
101-441-804.000	DOLLAR LAKE BOAT RAMP KEYS	0.00	200.00	0.00	0.00	200.00	0.00
101-441-827.000	INSURANCE-MMRMA	16,073.40	19,800.00	15,566.60	0.00	4,233.40	78.62
101-441-850.002	24/7 COMMUNICATION	540.00	720.00	540.00	60.00	180.00	75.00
101-441-920.000	UTILITIES	7,132.52	10,900.00	9,864.57	1,149.25	1,035.43	90.50
101-441-930.000	MAINTENANCE AND REPAIRS	2,932.17	9,000.00	3,909.36	0.00	5,090.64	43.44
101-441-933.000	DPW GROUNDS & MAINTANCE	265.00	7,500.00	1,237.76	0.00	6,262.24	16.50
101-441-955.000	TRAINING	0.00	500.00	30.00	0.00	470.00	6.00
Total Dept 441 - DEPT OF PUBLIC WORKS		66,671.83	157,920.00	103,557.18	3,338.34	54,362.82	65.58
Dept 448 - STREET LIGHTING							
101-448-920.000	UTILITIES	52,712.88	77,000.00	53,309.52	5,903.62	23,690.48	69.23
Total Dept 448 - STREET LIGHTING		52,712.88	77,000.00	53,309.52	5,903.62	23,690.48	69.23
Dept 528 - REFUSE COLLECTION SERVICES							
101-528-808.000	REFUSE COLLECTION SERVICES	161,586.00	238,082.00	176,999.70	20,112.30	61,082.30	74.34
101-528-808.001	RECYCLE	0.00	7,500.00	7,500.00	0.00	0.00	100.00

REVENUE AND EXPENDITURE REPORT FOR CITY OF KEEGO HARBOR
PERIOD ENDING 03/31/2026
% Fiscal Year Completed: 75.07

GL NUMBER	DESCRIPTION	YTD BALANCE 03/31/2025	2025-26 AMENDED BUDGET	YTD BALANCE 03/31/2026	ACTIVITY FOR MONTH 03/31/26	AVAILABLE BALANCE	% BDGT USED
Fund 101 - GENERAL FUND							
Expenditures							
Total Dept 528 - REFUSE COLLECTION SERVICES		161,586.00	245,582.00	184,499.70	20,112.30	61,082.30	75.13
Dept 694 - CDBG PROJECTS							
101-694-850.000	CDBG EXPENDITURES	13,673.00	10,175.00	0.00	0.00	10,175.00	0.00
Total Dept 694 - CDBG PROJECTS		13,673.00	10,175.00	0.00	0.00	10,175.00	0.00
Dept 722 - CODE ENFORCEMENT							
101-722-707.100	WAGES-P/T CODE ENFORCEMENT	11,093.50	24,400.00	8,097.33	901.25	16,302.67	33.19
101-722-711.000	FICA	848.67	1,850.00	617.24	68.95	1,232.76	33.36
101-722-725.000	FUEL	488.43	700.00	205.38	7.00	494.62	29.34
101-722-930.000	MAINTENANCE AND REPAIRS	0.00	1,200.00	0.00	0.00	1,200.00	0.00
Total Dept 722 - CODE ENFORCEMENT		12,430.60	28,150.00	8,919.95	977.20	19,230.05	31.69
Dept 774 - RECREATION ACTIVITIES							
101-774-728.000	SUPPLIES	80.00	900.00	375.57	0.00	524.43	41.73
101-774-802.000	PROFESSIONAL AND TECHNICAL SERV.	145.00	2,300.00	559.99	0.00	1,740.01	24.35
101-774-863.000	BUS TRANSPORTATION	0.00	2,000.00	0.00	0.00	2,000.00	0.00
101-774-882.000	COMMUNITY EVENTS	1,769.26	3,000.00	2,876.94	0.00	123.06	95.90
101-774-890.003	EASTER EXPENDITURES	726.17	800.00	661.81	661.81	138.19	82.73
101-774-890.004	WINTER WONDERLAND	1,002.03	1,000.00	995.22	0.00	4.78	99.52
101-774-890.005	MEMORIAL DAY PARADE	0.00	1,000.00	0.00	0.00	1,000.00	0.00
101-774-890.006	BLOCK PARTIES	1,167.58	3,000.00	1,736.44	0.00	1,263.56	57.88
101-774-890.007	GARDEN CLUE/TREES	369.31	200.00	0.00	0.00	200.00	0.00
101-774-930.000	MAINTENANCE AND REPAIRS	0.00	2,000.00	0.00	0.00	2,000.00	0.00
Total Dept 774 - RECREATION ACTIVITIES		5,259.35	16,200.00	7,205.97	661.81	8,994.03	44.48
Dept 899 - TAX TRIBUNAL/OTHER REFUNDS ORDERED							
101-899-956.000	TAX TRIBUNALS	0.00	1,500.00	10.93	0.00	1,489.07	0.73
Total Dept 899 - TAX TRIBUNAL/OTHER REFUNDS ORDERED		0.00	1,500.00	10.93	0.00	1,489.07	0.73
Dept 990 - DEBT SERVICE							
101-990-991.000	OC BUILDING BOND 2010 PRINCIPAL	30,000.00	30,000.00	30,000.00	0.00	0.00	100.00
101-990-992.000	OC BUILDING BOND 2010 INTEREST	11,943.75	20,888.00	10,443.75	0.00	10,444.25	50.00
Total Dept 990 - DEBT SERVICE		41,943.75	50,888.00	40,443.75	0.00	10,444.25	79.48
Dept 995 - OTHER FINANCING USES							
101-995-999.203	TRANSFER OUT LOCAL ROAD FUND	0.00	223,430.00	0.00	0.00	223,430.00	0.00
101-995-999.207	TRANSFER OUT - POLICE FUND	500,000.00	780,350.00	624,006.00	0.00	156,344.00	79.96
101-995-999.401	TRANSFER OUT - CAPITAL PROJECT	0.00	102,400.00	71,700.00	0.00	30,700.00	70.02
Total Dept 995 - OTHER FINANCING USES		500,000.00	1,106,180.00	695,706.00	0.00	410,474.00	62.89
TOTAL EXPENDITURES		1,840,434.22	2,995,032.00	2,170,966.86	206,714.82	824,065.14	72.49

REVENUE AND EXPENDITURE REPORT FOR CITY OF KEEGO HARBOR
PERIOD ENDING 03/31/2026
% Fiscal Year Completed: 75.07

GL NUMBER	DESCRIPTION	YTD BALANCE 03/31/2025	2025-26 AMENDED BUDGET	YTD BALANCE 03/31/2026	ACTIVITY FOR MONTH 03/31/26	AVAILABLE BALANCE	% BDGT USED
Fund 101 - GENERAL FUND							
Fund 101 - GENERAL FUND:							
	TOTAL REVENUES	2,193,756.26	2,584,695.00	2,253,702.38	12,954.15	330,992.62	87.19
	TOTAL EXPENDITURES	1,840,434.22	2,995,032.00	2,170,966.86	206,714.82	824,065.14	72.49
	NET OF REVENUES & EXPENDITURES	353,322.04	(410,337.00)	82,735.52	(193,760.67)	(493,072.52)	20.16

REVENUE AND EXPENDITURE REPORT FOR CITY OF KEEGO HARBOR
PERIOD ENDING 03/31/2026
% Fiscal Year Completed: 75.07

GL NUMBER	DESCRIPTION	YTD BALANCE 03/31/2025	2025-26 AMENDED BUDGET	YTD BALANCE 03/31/2026	ACTIVITY FOR MONTH 03/31/26	AVAILABLE BALANCE	% BDGT USED
Fund 202 - MAJOR STREET FUND							
Revenues							
Dept 000 - UNCLASSIFIED							
202-000-546.000	ACT 51 REVENUES	167,374.15	217,482.00	144,541.55	0.00	72,940.45	66.46
202-000-665.000	INTEREST	0.00	10.00	0.00	0.00	10.00	0.00
Total Dept 000 - UNCLASSIFIED		167,374.15	217,492.00	144,541.55	0.00	72,950.45	66.46
Dept 450 - WINTER MAINTENANCE							
202-450-650.000	ROAD SALT	1,386.67	1,200.00	901.26	0.00	298.74	75.11
Total Dept 450 - WINTER MAINTENANCE		1,386.67	1,200.00	901.26	0.00	298.74	75.11
Dept 460 - ROUTINE STREET MAINTENANCE							
202-460-675.002	COST RECOVERY - REIMBURSEMENT	0.00	2,000.00	2,900.00	0.00	(900.00)	145.00
202-460-675.003	COST RECOVERY - MMRMA	0.00	5,000.00	0.00	0.00	5,000.00	0.00
202-460-675.004	COST RECOVERY - LIGHT POLE	24,240.00	1,000.00	0.00	0.00	1,000.00	0.00
Total Dept 460 - ROUTINE STREET MAINTENANCE		24,240.00	8,000.00	2,900.00	0.00	5,100.00	36.25
TOTAL REVENUES		193,000.82	226,692.00	148,342.81	0.00	78,349.19	65.44
Expenditures							
Dept 000 - UNCLASSIFIED							
202-000-812.101	ADMINISTRATIVE CHARGES-TO 101	16,700.00	21,700.00	0.00	0.00	21,700.00	0.00
Total Dept 000 - UNCLASSIFIED		16,700.00	21,700.00	0.00	0.00	21,700.00	0.00
Dept 450 - WINTER MAINTENANCE							
202-450-702.000	WAGES-FULL TIME	5,608.71	6,500.00	6,236.72	859.14	263.28	95.95
202-450-711.000	FICA	429.07	497.00	477.11	65.72	19.89	96.00
202-450-725.000	FUEL	14.96	500.00	55.72	12.29	444.28	11.14
202-450-728.000	SUPPLIES	7,423.30	7,500.00	5,422.88	0.00	2,077.12	72.31
202-450-930.000	MAINTENANCE AND REPAIRS	34.10	1,000.00	134.77	0.00	865.23	13.48
202-450-935.000	STREET MAINTENANCE & REPAIR	434.30	10,000.00	0.00	0.00	10,000.00	0.00
202-450-944.000	RENTAL OF EQUIPMENT	1,773.53	7,500.00	2,655.35	0.00	4,844.65	35.40
Total Dept 450 - WINTER MAINTENANCE		15,717.97	33,497.00	14,982.55	937.15	18,514.45	44.73
Dept 460 - ROUTINE STREET MAINTENANCE							
202-460-702.000	WAGES-FULL TIME	6,433.10	8,300.00	6,768.56	0.00	1,531.44	81.55
202-460-711.000	FICA	492.12	635.00	517.99	0.00	117.01	81.57
202-460-725.000	FUEL	122.81	400.00	88.20	0.00	311.80	22.05
202-460-728.000	SUPPLIES	80.94	2,000.00	0.00	0.00	2,000.00	0.00
202-460-802.000	PROFESSIONAL AND TECHNICAL SERV.	0.00	2,000.00	0.00	0.00	2,000.00	0.00
202-460-930.000	MAINTENANCE AND REPAIRS	75.90	10,000.00	161.57	0.00	9,838.43	1.62
202-460-930.004	MAINT & REPAIR-LIGHT POLE	24,240.00	2,000.00	0.00	0.00	2,000.00	0.00
202-460-944.000	RENTAL OF EQUIPMENT	6,319.78	12,000.00	5,776.37	838.26	6,223.63	48.14
Total Dept 460 - ROUTINE STREET MAINTENANCE		37,764.65	37,335.00	13,312.69	838.26	24,022.31	35.66
Dept 462 - TRAFFIC SERVICES							

REVENUE AND EXPENDITURE REPORT FOR CITY OF KEEGO HARBOR
PERIOD ENDING 03/31/2026
% Fiscal Year Completed: 75.07

GL NUMBER	DESCRIPTION	YTD BALANCE 03/31/2025	2025-26 AMENDED BUDGET	YTD BALANCE 03/31/2026	ACTIVITY FOR MONTH 03/31/26	AVAILABLE BALANCE	% BDGT USED
Fund 202 - MAJOR STREET FUND							
Expenditures							
202-462-806.000	CONTRACTED SERVICES	915.08	2,000.00	329.05	147.47	1,670.95	16.45
Total Dept 462 - TRAFFIC SERVICES		915.08	2,000.00	329.05	147.47	1,670.95	16.45
Dept 466 - ROAD PRESERVATION							
202-466-930.006	STREET PROJECT	0.00	65,000.00	0.00	0.00	65,000.00	0.00
Total Dept 466 - ROAD PRESERVATION		0.00	65,000.00	0.00	0.00	65,000.00	0.00
Dept 995 - OTHER FINANCING USES							
202-995-999.203	TRANSFER OUT LOCAL ROAD FUND	180,000.00	180,000.00	180,000.00	0.00	0.00	100.00
Total Dept 995 - OTHER FINANCING USES		180,000.00	180,000.00	180,000.00	0.00	0.00	100.00
TOTAL EXPENDITURES		251,097.70	339,532.00	208,624.29	1,922.88	130,907.71	61.44
Fund 202 - MAJOR STREET FUND:							
TOTAL REVENUES		193,000.82	226,692.00	148,342.81	0.00	78,349.19	65.44
TOTAL EXPENDITURES		251,097.70	339,532.00	208,624.29	1,922.88	130,907.71	61.44
NET OF REVENUES & EXPENDITURES		(58,096.88)	(112,840.00)	(60,281.48)	(1,922.88)	(52,558.52)	53.42

REVENUE AND EXPENDITURE REPORT FOR CITY OF KEEGO HARBOR
PERIOD ENDING 03/31/2026
% Fiscal Year Completed: 75.07

GL NUMBER	DESCRIPTION	YTD BALANCE 03/31/2025	2025-26 AMENDED BUDGET	YTD BALANCE 03/31/2026	ACTIVITY FOR MONTH 03/31/26	AVAILABLE BALANCE	% BDGT USED
Fund 203 - LOCAL STREET FUND							
Revenues							
Dept 000 - UNCLASSIFIED							
203-000-546.000	ACT 51 REVENUES	71,810.54	93,278.00	62,021.76	0.00	31,256.24	66.49
203-000-574.100	METRO ACT FUNDING	0.00	9,000.00	0.00	0.00	9,000.00	0.00
203-000-624.000	STATE GRANT	0.00	500,000.00	0.00	0.00	500,000.00	0.00
203-000-627.202	CONTRIBUTION/ADMIN FROM 202 MAJ	180,000.00	180,000.00	180,000.00	0.00	0.00	100.00
203-000-665.000	INTEREST	0.00	10.00	0.00	0.00	10.00	0.00
203-000-699.101	TRANSFERS-IN FR GENERAL	0.00	223,430.00	0.00	0.00	223,430.00	0.00
Total Dept 000 - UNCLASSIFIED		251,810.54	1,005,718.00	242,021.76	0.00	763,696.24	24.06
Dept 450 - WINTER MAINTENANCE							
203-450-650.000	ROAD SALT	4,916.39	5,000.00	3,195.36	0.00	1,804.64	63.91
Total Dept 450 - WINTER MAINTENANCE		4,916.39	5,000.00	3,195.36	0.00	1,804.64	63.91
TOTAL REVENUES		256,726.93	1,010,718.00	245,217.12	0.00	765,500.88	24.26
Expenditures							
Dept 000 - UNCLASSIFIED							
203-000-812.101	ADMINISTRATIVE CHARGES-TO 101	7,100.00	9,300.00	0.00	0.00	9,300.00	0.00
Total Dept 000 - UNCLASSIFIED		7,100.00	9,300.00	0.00	0.00	9,300.00	0.00
Dept 450 - WINTER MAINTENANCE							
203-450-702.000	WAGES-FULL TIME	3,915.50	5,300.00	8,241.38	2,227.40	(2,941.38)	155.50
203-450-704.000	OVERTIME	0.00	0.00	99.80	0.00	(99.80)	100.00
203-450-711.000	FICA	299.54	406.00	729.21	221.51	(323.21)	179.61
203-450-725.000	FUEL	53.04	1,300.00	197.58	43.57	1,102.42	15.20
203-450-728.000	SUPPLIES	12,017.22	12,000.00	15,238.68	0.00	(3,238.68)	126.99
203-450-802.000	PROFESSIONAL SERVICES	0.00	1,500.00	0.00	0.00	1,500.00	0.00
203-450-930.000	MAINTENANCE AND REPAIRS	1,120.90	2,000.00	477.87	0.00	1,522.13	23.89
203-450-944.000	RENTAL OF EQUIPMENT	1,960.85	6,000.00	388.53	0.00	5,611.47	6.48
Total Dept 450 - WINTER MAINTENANCE		19,367.05	28,506.00	25,373.05	2,492.48	3,132.95	89.01
Dept 460 - ROUTINE STREET MAINTENANCE							
203-460-702.000	WAGES-FULL TIME	7,379.80	8,500.00	9,024.34	0.00	(524.34)	106.17
203-460-704.000	OVERTIME	0.00	1,000.00	0.00	0.00	1,000.00	0.00
203-460-711.000	FICA	564.55	688.00	863.35	0.00	(175.35)	125.49
203-460-725.000	FUEL	435.40	1,000.00	312.68	0.00	687.32	31.27
203-460-728.000	SUPPLIES	0.00	2,000.00	0.00	0.00	2,000.00	0.00
203-460-728.001	METRO ACT- RIGHT OF WAY	0.00	2,000.00	0.00	0.00	2,000.00	0.00
203-460-802.107	BRIDGE INSPECTION	0.00	3,500.00	0.00	0.00	3,500.00	0.00
203-460-930.000	MAINTENANCE AND REPAIRS	269.10	3,000.00	0.00	0.00	3,000.00	0.00
203-460-935.000	STREET MAINTENANCE & REPAIR	1,060.16	25,000.00	572.83	0.00	24,427.17	2.29
203-460-944.000	RENTAL OF EQUIPMENT	6,582.21	11,500.00	11,824.72	2,213.64	(324.72)	102.82
Total Dept 460 - ROUTINE STREET MAINTENANCE		16,291.22	58,188.00	22,597.92	2,213.64	35,590.08	38.84
Dept 466 - ROAD PRESERVATION							
203-466-930.006	STREET PROJECT	47,541.89	280,000.00	206,555.64	0.00	73,444.36	73.77

REVENUE AND EXPENDITURE REPORT FOR CITY OF KEEGO HARBOR
PERIOD ENDING 03/31/2026
% Fiscal Year Completed: 75.07

GL NUMBER	DESCRIPTION	YTD BALANCE 03/31/2025	2025-26 AMENDED BUDGET	YTD BALANCE 03/31/2026	ACTIVITY FOR MONTH 03/31/26	AVAILABLE BALANCE	% BDGT USED
Fund 203 - LOCAL STREET FUND							
Expenditures							
203-466-930.007	BRIDGE PROJECT	0.00	723,430.00	26,544.31	26,544.31	696,885.69	3.67
Total Dept 466 - ROAD PRESERVATION		47,541.89	1,003,430.00	233,099.95	26,544.31	770,330.05	23.23
TOTAL EXPENDITURES		90,300.16	1,099,424.00	281,070.92	31,250.43	818,353.08	25.57
Fund 203 - LOCAL STREET FUND:							
TOTAL REVENUES		256,726.93	1,010,718.00	245,217.12	0.00	765,500.88	24.26
TOTAL EXPENDITURES		90,300.16	1,099,424.00	281,070.92	31,250.43	818,353.08	25.57
NET OF REVENUES & EXPENDITURES		166,426.77	(88,706.00)	(35,853.80)	(31,250.43)	(52,852.20)	40.42

REVENUE AND EXPENDITURE REPORT FOR CITY OF KEEGO HARBOR
PERIOD ENDING 03/31/2026
% Fiscal Year Completed: 75.07

GL NUMBER	DESCRIPTION	YTD BALANCE 03/31/2025	2025-26 AMENDED BUDGET	YTD BALANCE 03/31/2026	ACTIVITY FOR MONTH 03/31/26	AVAILABLE BALANCE	% BDGT USED
Fund 207 - POLICE FUND							
Revenues							
Dept 000 - UNCLASSIFIED							
207-000-402.000	CURRENT TAXES	429,198.43	459,200.00	446,522.06	0.00	12,677.94	97.24
207-000-528.003	STATE GRANT - MARINE	0.00	50,000.00	50,000.00	0.00	0.00	100.00
207-000-543.000	ACT 302 REVENUES	998.35	800.00	1,048.00	0.00	(248.00)	131.00
207-000-545.000	LIQUOR LICENSE	4,298.25	6,000.00	4,743.05	0.00	1,256.95	79.05
207-000-631.000	RESTITUTION-POLICE	80.00	500.00	162.00	0.00	338.00	32.40
207-000-632.000	COURT COST RECOVERY-OWI	304.00	1,200.00	2,669.09	0.00	(1,469.09)	222.42
207-000-634.000	SOR	545.00	200.00	141.49	0.00	58.51	70.75
207-000-635.000	POLICE REPORTS	134.73	700.00	341.85	65.01	358.15	48.84
207-000-636.000	FINGERPRINT/BREATHALYZER	5.00	750.00	0.00	0.00	750.00	0.00
207-000-637.000	IMPOUND	240.00	600.00	540.00	0.00	60.00	90.00
207-000-643.901	BOAT KEY-MARINE PORTION	120.00	100.00	80.00	0.00	20.00	80.00
207-000-670.000	TRAINING	5,000.00	500.00	5,397.50	0.00	(4,897.50)	1,079.50
207-000-675.000	COST REC- MISC/REIMBURSEMENT	0.00	900.00	896.25	0.00	3.75	99.58
207-000-699.101	TRANSFERS-IN FR GENERAL	500,000.00	780,350.00	624,006.00	0.00	156,344.00	79.96
Total Dept 000 - UNCLASSIFIED		940,923.76	1,301,800.00	1,136,547.29	65.01	165,252.71	87.31
TOTAL REVENUES		940,923.76	1,301,800.00	1,136,547.29	65.01	165,252.71	87.31
Expenditures							
Dept 000 - UNCLASSIFIED							
207-000-702.000	WAGES-FULL TIME	244,847.42	418,000.00	317,090.88	59,425.43	100,909.12	75.86
207-000-704.000	OVERTIME	27,490.39	32,000.00	39,479.42	10,244.50	(7,479.42)	123.37
207-000-706.000	HOLIDAY PAY (PD)	12,009.68	19,000.00	16,009.36	0.00	2,990.64	84.26
207-000-707.000	WAGES- PART TIME/SEASONAL	53,883.12	76,000.00	46,508.09	4,353.02	29,491.91	61.19
207-000-708.000	UNIFORM ALLOWANCE	9,264.90	10,000.00	6,577.89	0.00	3,422.11	65.78
207-000-710.000	MARINE PATROL	57,795.20	58,000.00	17,437.12	0.00	40,562.88	30.06
207-000-711.000	FICA	25,063.03	39,300.00	30,794.07	5,070.71	8,505.93	78.36
207-000-711.004	HEALTH INSURANCE	59,059.48	86,000.00	68,447.13	5,203.81	17,552.87	79.59
207-000-711.005	RETIREMENT PLAN	94,992.57	185,500.00	158,972.41	10,313.00	26,527.59	85.70
207-000-711.006	LIFE INSURANCE	2,026.88	3,100.00	3,229.66	384.58	(129.66)	104.18
207-000-711.007	WORKERS COMP	546.93	8,400.00	793.28	793.28	7,606.72	9.44
207-000-711.008	UNEMPLOYMENT	17.46	300.00	6.11	0.00	293.89	2.04
207-000-711.011	CELL PHONE ALLOWANCE	0.00	2,000.00	1,500.03	166.67	499.97	75.00
207-000-711.014	HEALTH INSURANCE OPT OUT	2,192.22	3,000.00	2,307.60	346.14	692.40	76.92
207-000-725.000	FUEL	10,881.21	16,000.00	11,593.35	838.77	4,406.65	72.46
207-000-728.000	SUPPLIES	5,863.27	10,000.00	2,464.73	233.38	7,535.27	24.65
207-000-730.001	EQUIPMENT - BODY CAMERAS	9,461.39	500.00	0.00	0.00	500.00	0.00
207-000-800.101	LEGAL FEES-GENERAL PERSONNEL	47,311.50	63,000.00	46,402.00	9,847.00	16,598.00	73.65
207-000-800.300	CONTRACTED SERVICE	948.70	1,500.00	0.00	0.00	1,500.00	0.00
207-000-813.000	INTERGOVERNMENTAL SERVICES AGREI	59,068.31	87,000.00	62,506.29	0.00	24,493.71	71.85
207-000-827.000	INSURANCE-MMRMA	60,275.26	63,000.00	68,218.49	0.00	(5,218.49)	108.28
207-000-850.000	TELEPHONE	1,975.31	2,500.00	1,955.12	216.99	544.88	78.20
207-000-920.000	UTILITIES	8,356.52	10,000.00	9,265.11	1,137.36	734.89	92.65
207-000-930.000	MAINTENANCE AND REPAIRS	5,292.00	8,000.00	5,578.37	(492.17)	2,421.63	69.73
207-000-944.001	COPIER & MAINTENANCE	0.00	500.00	0.00	0.00	500.00	0.00
207-000-954.000	ACT 302 TRAINING	0.00	2,000.00	0.00	0.00	2,000.00	0.00
207-000-955.000	PROF DEVELOPMENT/TRAINING	4,472.95	8,000.00	2,939.00	0.00	5,061.00	36.74
207-000-999.401	TRANSFERS OUT CAPITAL PROJECTS	0.00	89,200.00	99,980.00	0.00	(10,780.00)	112.09
Total Dept 000 - UNCLASSIFIED		803,095.70	1,301,800.00	1,020,055.51	108,082.47	281,744.49	78.36

REVENUE AND EXPENDITURE REPORT FOR CITY OF KEEGO HARBOR
PERIOD ENDING 03/31/2026
% Fiscal Year Completed: 75.07

GL NUMBER	DESCRIPTION	YTD BALANCE 03/31/2025	2025-26 AMENDED BUDGET	YTD BALANCE 03/31/2026	ACTIVITY FOR MONTH 03/31/26	AVAILABLE BALANCE	% BDGT USED
Fund 207 - POLICE FUND							
Expenditures							
TOTAL EXPENDITURES		803,095.70	1,301,800.00	1,020,055.51	108,082.47	281,744.49	78.36
<hr/>							
Fund 207 - POLICE FUND:							
TOTAL REVENUES		940,923.76	1,301,800.00	1,136,547.29	65.01	165,252.71	87.31
TOTAL EXPENDITURES		803,095.70	1,301,800.00	1,020,055.51	108,082.47	281,744.49	78.36
NET OF REVENUES & EXPENDITURES		137,828.06	0.00	116,491.78	(108,017.46)	(116,491.78)	100.00

REVENUE AND EXPENDITURE REPORT FOR CITY OF KEEGO HARBOR
PERIOD ENDING 03/31/2026
% Fiscal Year Completed: 75.07

GL NUMBER	DESCRIPTION	YTD BALANCE 03/31/2025	2025-26 AMENDED BUDGET	YTD BALANCE 03/31/2026	ACTIVITY FOR MONTH 03/31/26	AVAILABLE BALANCE	% BDGT USED
Fund 247 - TAX INCREMENT FINANCE AUTHOR FUND							
Revenues							
Dept 000 - UNCLASSIFIED							
247-000-402.000	CURRENT TAXES	325,573.85	337,700.00	320,743.52	0.00	16,956.48	94.98
247-000-573.000	LOCAL COMMUNITY STABILIZATION SI	2,457.92	2,500.00	0.00	0.00	2,500.00	0.00
Total Dept 000 - UNCLASSIFIED		328,031.77	340,200.00	320,743.52	0.00	19,456.48	94.28
TOTAL REVENUES		328,031.77	340,200.00	320,743.52	0.00	19,456.48	94.28
Expenditures							
Dept 000 - UNCLASSIFIED							
247-000-964.000	MISC EXPENSE	0.00	1,500.00	0.00	0.00	1,500.00	0.00
Total Dept 000 - UNCLASSIFIED		0.00	1,500.00	0.00	0.00	1,500.00	0.00
Dept 191 - ADMINISTRATION							
247-191-802.000	PROFESSIONAL AND TECHNICAL SERV	79,737.03	50,000.00	10,227.04	1,823.28	39,772.96	20.45
Total Dept 191 - ADMINISTRATION		79,737.03	50,000.00	10,227.04	1,823.28	39,772.96	20.45
Dept 693 - CASS LAKE ROAD							
247-693-702.000	WAGES-FULL TIME	0.00	32,500.00	31,925.10	3,364.64	574.90	98.23
247-693-711.000	FICA	0.00	3,060.00	2,441.80	257.12	618.20	79.80
247-693-711.004	HEALTH INSURANCE	0.00	10,000.00	6,626.78	326.90	3,373.22	66.27
247-693-711.005	RETIREMENT PLAN	0.00	2,600.00	1,015.40	0.00	1,584.60	39.05
247-693-711.006	LIFE INSURANCE	0.00	350.00	0.00	0.00	350.00	0.00
247-693-711.007	WORKERS COMP	0.00	400.00	0.00	0.00	400.00	0.00
247-693-812.000	ADMINISTRATION CHARGES	48,195.00	50,408.00	50,408.00	0.00	0.00	100.00
247-693-830.005	FACADE IMPROVEMENTS - PROGRAM	0.00	50,000.00	0.00	0.00	50,000.00	0.00
247-693-944.000	RENTAL OF EQUIPMENT	1,802.90	12,000.00	8,980.47	842.52	3,019.53	74.84
247-693-970.000	CAPITAL EXPENSES	27,697.17	150,000.00	14,901.62	0.00	135,098.38	9.93
Total Dept 693 - CASS LAKE ROAD		77,695.07	311,318.00	116,299.17	4,791.18	195,018.83	37.36
Dept 899 - TAX TRIBUNAL/OTHER REFUNDS ORDERED							
247-899-956.000	COSTS, FEES, AND CHARGES	347.40	700.00	172.86	0.00	527.14	24.69
Total Dept 899 - TAX TRIBUNAL/OTHER REFUNDS ORDERED		347.40	700.00	172.86	0.00	527.14	24.69
Dept 965 - APPROPRIATED TRANSFERS OUT							
247-965-999.353	TRANSFER OUT TO TIFA 2013 DEBT	71,608.45	0.00	0.00	0.00	0.00	0.00
Total Dept 965 - APPROPRIATED TRANSFERS OUT		71,608.45	0.00	0.00	0.00	0.00	0.00
TOTAL EXPENDITURES		229,387.95	363,518.00	126,699.07	6,614.46	236,818.93	34.85
Fund 247 - TAX INCREMENT FINANCE AUTHOR FUND:							
TOTAL REVENUES		328,031.77	340,200.00	320,743.52	0.00	19,456.48	94.28

REVENUE AND EXPENDITURE REPORT FOR CITY OF KEEGO HARBOR
PERIOD ENDING 03/31/2026
% Fiscal Year Completed: 75.07

GL NUMBER	DESCRIPTION	YTD BALANCE 03/31/2025	2025-26 AMENDED BUDGET	YTD BALANCE 03/31/2026	ACTIVITY FOR MONTH 03/31/26	AVAILABLE BALANCE	% BDGT USED
Fund 247 - TAX INCREMENT FINANCE AUTHOR FUND							
TOTAL EXPENDITURES		229,387.95	363,518.00	126,699.07	6,614.46	236,818.93	34.85
NET OF REVENUES & EXPENDITURES		98,643.82	(23,318.00)	194,044.45	(6,614.46)	(217,362.45)	832.17

REVENUE AND EXPENDITURE REPORT FOR CITY OF KEEGO HARBOR
PERIOD ENDING 03/31/2026
% Fiscal Year Completed: 75.07

GL NUMBER	DESCRIPTION	YTD BALANCE 03/31/2025	2025-26 AMENDED BUDGET	YTD BALANCE 03/31/2026	ACTIVITY FOR MONTH 03/31/26	AVAILABLE BALANCE	% BDGT USED
Fund 271 - LIBRARY MILLAGE FUND							
Revenues							
Dept 000 - UNCLASSIFIED							
271-000-402.000	CURRENT TAXES	34,807.60	37,100.00	36,012.05	0.00	1,087.95	97.07
Total Dept 000 - UNCLASSIFIED		34,807.60	37,100.00	36,012.05	0.00	1,087.95	97.07
TOTAL REVENUES		34,807.60	37,100.00	36,012.05	0.00	1,087.95	97.07
Expenditures							
Dept 790 - LIBRARY SERVICES							
271-790-813.000	INTERGOVERNMENTAL SERVICES AGREI	34,532.56	37,100.00	38,301.64	0.00	(1,201.64)	103.24
Total Dept 790 - LIBRARY SERVICES		34,532.56	37,100.00	38,301.64	0.00	(1,201.64)	103.24
TOTAL EXPENDITURES		34,532.56	37,100.00	38,301.64	0.00	(1,201.64)	103.24
Fund 271 - LIBRARY MILLAGE FUND:							
TOTAL REVENUES		34,807.60	37,100.00	36,012.05	0.00	1,087.95	97.07
TOTAL EXPENDITURES		34,532.56	37,100.00	38,301.64	0.00	(1,201.64)	103.24
NET OF REVENUES & EXPENDITURES		275.04	0.00	(2,289.59)	0.00	2,289.59	100.00

REVENUE AND EXPENDITURE REPORT FOR CITY OF KEEGO HARBOR
PERIOD ENDING 03/31/2026
% Fiscal Year Completed: 75.07

GL NUMBER	DESCRIPTION	YTD BALANCE 03/31/2025	2025-26 AMENDED BUDGET	YTD BALANCE 03/31/2026	ACTIVITY FOR MONTH 03/31/26	AVAILABLE BALANCE	% BDGT USED
Fund 401 - CAPITAL PROJECTS FUND							
Revenues							
Dept 000 - UNCLASSIFIED							
401-000-695.001	SALE OF ASSETS-DPW	800.00	0.00	0.00	0.00	0.00	0.00
401-000-695.002	SALE OF ASSETS-POLICE	7,920.00	0.00	0.00	0.00	0.00	0.00
401-000-699.101	TRANSFERS-IN FR GENERAL	0.00	102,400.00	71,700.00	0.00	30,700.00	70.02
401-000-699.207	TRANSFER IN FROM POLICE FUND	0.00	89,200.00	99,980.00	0.00	(10,780.00)	112.09
401-000-699.300	APPROPRIATION FROM PY FUND BAL	0.00	45,000.00	0.00	0.00	45,000.00	0.00
Total Dept 000 - UNCLASSIFIED		8,720.00	236,600.00	171,680.00	0.00	64,920.00	72.56
TOTAL REVENUES		8,720.00	236,600.00	171,680.00	0.00	64,920.00	72.56
Expenditures							
Dept 101 - CITY COUNCIL							
401-101-970.000	CAPITAL EXPENSES	0.00	72,400.00	72,376.90	0.00	23.10	99.97
Total Dept 101 - CITY COUNCIL		0.00	72,400.00	72,376.90	0.00	23.10	99.97
Dept 207 - POLICE IN CAR COMPUTERS							
401-207-981.003	POLICE EQUIPMENT	7,408.60	109,200.00	86,198.44	6,972.96	23,001.56	78.94
Total Dept 207 - POLICE IN CAR COMPUTERS		7,408.60	109,200.00	86,198.44	6,972.96	23,001.56	78.94
Dept 441 - DEPT OF PUBLIC WORKS							
401-441-970.000	CAPITAL EXPENSES	0.00	55,000.00	0.00	0.00	55,000.00	0.00
Total Dept 441 - DEPT OF PUBLIC WORKS		0.00	55,000.00	0.00	0.00	55,000.00	0.00
TOTAL EXPENDITURES		7,408.60	236,600.00	158,575.34	6,972.96	78,024.66	67.02
Fund 401 - CAPITAL PROJECTS FUND:							
TOTAL REVENUES		8,720.00	236,600.00	171,680.00	0.00	64,920.00	72.56
TOTAL EXPENDITURES		7,408.60	236,600.00	158,575.34	6,972.96	78,024.66	67.02
NET OF REVENUES & EXPENDITURES		1,311.40	0.00	13,104.66	(6,972.96)	(13,104.66)	100.00

REVENUE AND EXPENDITURE REPORT FOR CITY OF KEEGO HARBOR
PERIOD ENDING 03/31/2026
% Fiscal Year Completed: 75.07

GL NUMBER	DESCRIPTION	YTD BALANCE 03/31/2025	2025-26 AMENDED BUDGET	YTD BALANCE 03/31/2026	ACTIVITY FOR MONTH 03/31/26	AVAILABLE BALANCE	% BDGT USED
Fund 592 - WATER & SEWER FUND							
Revenues							
Dept 000 - UNCLASSIFIED							
592-000-451.120	MISC PERMIT	3,180.00	2,400.00	0.00	0.00	2,400.00	0.00
592-000-528.002	ARPA GRANT	0.00	125,000.00	0.00	0.00	125,000.00	0.00
592-000-528.004	CRITICAL INFRASTRUCTURE GRANT	0.00	100,000.00	41,948.61	0.00	58,051.39	41.95
592-000-601.000	WATER AND SEWER FLAT FEE	11,122.04	14,500.00	11,135.08	3,703.00	3,364.92	76.79
Total Dept 000 - UNCLASSIFIED		14,302.04	241,900.00	53,083.69	3,703.00	188,816.31	21.94
TOTAL REVENUES		14,302.04	241,900.00	53,083.69	3,703.00	188,816.31	21.94
Expenditures							
Dept 000 - UNCLASSIFIED							
592-000-930.000	MAINTENANCE AND REPAIRS	0.00	5,000.00	0.00	0.00	5,000.00	0.00
592-000-930.001	GENERAL CAPITAL OUTLAY	0.00	53,000.00	0.00	0.00	53,000.00	0.00
592-000-931.001	BEECHMONT DRAIN LIFT STATION	0.00	25,000.00	0.00	0.00	25,000.00	0.00
592-000-932.001	LSLR LEAD SER. LINE REPLACEMENT	0.00	200,000.00	24,949.00	4,615.46	175,051.00	12.47
Total Dept 000 - UNCLASSIFIED		0.00	283,000.00	24,949.00	4,615.46	258,051.00	8.82
TOTAL EXPENDITURES		0.00	283,000.00	24,949.00	4,615.46	258,051.00	8.82
Fund 592 - WATER & SEWER FUND:							
TOTAL REVENUES		14,302.04	241,900.00	53,083.69	3,703.00	188,816.31	21.94
TOTAL EXPENDITURES		0.00	283,000.00	24,949.00	4,615.46	258,051.00	8.82
NET OF REVENUES & EXPENDITURES		14,302.04	(41,100.00)	28,134.69	(912.46)	(69,234.69)	68.45
TOTAL REVENUES - ALL FUNDS							
TOTAL REVENUES - ALL FUNDS		3,970,269.18	5,979,705.00	4,365,328.86	16,722.16	1,614,376.14	73.00
TOTAL EXPENDITURES - ALL FUNDS		3,256,256.89	6,656,006.00	4,029,242.63	366,173.48	2,626,763.37	60.54
NET OF REVENUES & EXPENDITURES		714,012.29	(676,301.00)	336,086.23	(349,451.32)	(1,012,387.23)	49.69

CITY OF KEEGO HARBOR
STUDY SESSION MEETING MINUTES
Tuesday, March 17, 2026, 7:00 PM
2025 Beechmont St.
Keego Harbor, MI 48320

CALL THE MEETING TO ORDER

Mayor Ross called the meeting to order at 7:00 PM

ROLL CALL:

Present: Mayor Joel Ross, Mayor Pro Tem Rob Kalman, Council Member John Fletcher, Council Member Cristina Elsen, Council Member Corine Streng

STAFF PRESENT: City Manager / City Clerk Tammy Neeb, City Planner Emily Huhuman, and Chief Barnes.

PLEDGE OF ALLEGIANCE

PUBLIC COMMENT:

Public comments were made.

APPROVAL OF AGENDA

Motion by Council Member Streng, support by Elsen to add a discussion about the proposal for 2026 Graduation Flags and Banner to the agenda.

Unanimous Vote: Ayes: 5 Nays: 0

Motion Carries

Motion by Council Member Elsen, support by Council Member Fletcher to approve the agenda for March 17th as amended.

Unanimous Vote: Ayes: 5 Nays: 0

Motion Carries

AGENDA ITEMS

Budget Amendments

City Manager Neeb reviewed the budget amendments including the Willow Beach Bridge project, the purchase of the police vehicle, the police officer retirement, and the possible purchase of the DPW truck.

City Hall- New Copier

The city hall copier is at end-of-life and needs to be replaced. Nolan Lane from Applied Innovations presented a proposal. The board would like a more

in-depth cost analysis and breakdown. They also requested a digital option.

DPW Truck Purchase

DPW Foreman Doug Waldon presented the request to replace the 14-year-old truck and provided quotes. \$55,000 was already budgeted.

TIFA Expenditures

- **Contracted Maintenance:** DPW would like to contract lawn maintenance for the TIFA district and TIFA recommended Kennedy Lawn and Snow. The city attorney will need to review the contract.
- **Street Sweeping:** Eagle Eye was recommended by TIFA to complete the street sweeping again this year for the Memorial Parade.
- **Kayak Launch Signs:** TIFA allocated \$300 for kayak launch signs at Dollar Lake.

TIFA -Fran Leaf Park Arch/Developer's Day

The city council supported the idea of an arch; it will be a focal point for the city. Developer's day would be held for real estate and infrastructure developers to get a better understanding of the future vision of Keego Harbor.

2890 Orchard Lake Road-Corner Property

TIFA requested a "For Sale" sign to be placed on the corner property before developer's day and will cover the cost of the sign.

2026 Recycling Events Increase

The cost increase for the West Bloomfield recycling event was covered by the city in 2025. City Council members discussed potentially covering the cost again this year.

2026 Goals and Objectives: City Hall Repairs and City Logo

City Council needs more information and a report listing the needed repairs. The city received several proposals through an RFI. City Planner, Ms. Huhuman provided a proposal from Mckenna for a new city logo. City Council and residents discussed city entrance signs.

TIGRIS Aquatic Contract

Annual pond and canal treatment agreement.

2026 Tri-Party Program-RCOC, Oakland County Commissioner, The City of Keego Harbor

The allocated costs for the city are being requested by RCOC and the County

Commissioner to be rolled over for road repairs.

Resolution 26-05 Great Lakes Water Authority Amendment No. 5 to the Water Service Contract

A few changes have been made to the agreement. City Council requested to see the specific changes that were made to the contract.

City Social Media

City Council discussed a social media presence to get information to the residents. Social media archiving may be necessary to move forward with a Facebook page for the city. Policy and procedures will be discussed.

Televised City Council Meetings

The funds to televise city council meetings will come out of the general fund. Meetings will resume on Civic Center TV.

Resolution 26-06 Planning Commission Recommendation

The City Attorney drafted the resolution with the discussed changes to the Planning Commission.

Oakland County Treasurer Tax Foreclosure Prevention

This will be placed on file and read in the mayor's announcement on Thursday.

Resolution 26-08 Opposition to HB 5529

The City Attorney will present this resolution on Thursday.

Graduation Banner and Flags

City Council Member Elsen presented the idea to post a banner with flags as a recognition to our graduating students.

Motion by Council Member Fletcher; supported by Mayor Ross to add this to Thursday night's agenda.

Unanimous Vote: Ayes: 5

Nays: 0

Motion Carries

CITY COUNCIL COMMENTS

Meeting adjourned at 9:05 p.m.

**CITY OF KEEGO HARBOR
CITY COUNCIL MEETING MINUTES
Thursday, March 19, 2026, AT 7:00 PM
2025 Beechmont St.
Keego Harbor, MI 48320**

CALL THE MEETING TO ORDER:

Mayor Ross called the meeting to order at 7:00 PM

ROLL CALL: Mayor Joel Ross, Mayor Pro Tem Rob Kalman, Council Member John Fletcher, Council Member Corine Streng, and Council Member Cristina Elsen

STAFF PRESENT: City Manager Tammy Neeb, Chief Robert Barnes, and City Attorney Tony Chubb.

PLEDGE OF ALLEGIANCE

PUBLIC COMMENT: (non-agenda items only)

Public comments were made.

ANNOUNCEMENTS:

- Mayor
- Planning Commission
- Parks and Recreation
- TIFA
- Police Chief
- City Attorney
- City Manager

APPROVAL OF AGENDA

Motion by Council Member Elsen; supported by Council Member Fletcher to approve the agenda for Thursday, March 19th.

Unanimous Vote: Ayes: 5 Nays: 0

Motion Carries

CONSENT AGENDA: Resolution 26-04

Monthly Financial Report

1. Authorize Bill payments for February 2026
2. Revenue and Expenditure Report

Meeting Minutes

- 3. February 17, 2026, Study Session Meeting Minutes
- 4. February 19, 2026, City Council Meeting Minutes

Resolution by Council Member Fletcher; supported by Mayor Pro Tem Kalman to approve the consent agenda.

Roll call: Ross yes, Kalman yes, Fletcher yes, Elsen yes, Streng yes.

Resolution Carries

REGULAR AGENDA:

Budget Amendments

Resolution by Mayor Pro Tem Kalman; supported by Council Member Fletcher to approve Resolution 26-07 for the budget amendments as presented.

Roll Call: Streng yes, Elsen yes, Ross yes, Fletcher yes, Kalman yes.

Resolution Carries

City Hall – New Copier

Motion by Mayor Ross; supported by Council Member Elsen to table.

Unanimous Vote: Ayes: 5 Nays: 0

Motion Carries

DPW Truck Purchase

The city has \$25,000 in reserve and an additional \$30,000 allocated in this year's budget to replace the 2012 DPW truck. The new truck will cost \$47,873, plus \$3,714.55 for transferring the plowing equipment.

Resolution by Mayor Pro Tem Kalman; supported by Council Member Fletcher to approve authorizing City Manager Neeb to purchase a 2026 F-350 in the amount of \$47,873 from Gorno Brothers Ford.

Roll Call: Kalman yes, Elsen yes, Ross yes, Fletcher yes, Streng yes.

Resolution Carries

Resolution by Council Member Streng; supported by Council Member Elsen to approve City Manager Neeb to purchase the outfitting package from Bostick not to exceed \$4,000.

Roll Call: Kalman yes, Elsen yes, Ross yes, Fletcher yes, Streng yes.

Resolution Carries

TIFA Expenditures

- **Contract Maintenance**

Resolution by Council Member Fletcher; supported by Council Member Elsen to budget up to \$30,000 for mowing, lawn care and other expenses in the TIFA district as present by the TIFA district.

Roll Call: Streng yes, Fletcher yes, Ross yes, Elsen yes, Kalman yes.

Resolution Carries

- **Street Sweeping-Memorial Day Parade**

Resolution by Council Member Elsen; supported by Council Member Fletcher to allocate up to \$620 to Eagle Eye Parking Lot Sweeping & Company for the purpose of the Memorial Day Parade.

Roll Call: Fletcher yes, Elsen yes, Kalman yes, Streng yes, Ross yes.

Resolution Carries

- **Kayak Launch Signs**

Resolution by Council Member Streng; supported by Mayor Ross to approve signs to be purchased for the kayak launch not to exceed \$500.

Roll Call: Kalman yes, Streng yes, Ross yes, Fletcher yes, Elsen yes.

Resolution Carries

2026 Recycling Events Increase

The city will cover the increased costs again and not pass on the tax increase to the residents.

Resolution by Council Member Fletcher; supported by Council Member Elsen the city will pay for the \$2,500 increase in the recycling event of interest earned out of the general fund.

Roll Call: Elsen yes, Fletcher yes, Streng yes, Ross yes Kalman yes.

Resolution Carries

2026 Goals and Objectives: City Hall Repairs and City Logo

- **City Hall Repairs:** City hall is 19 years old and needs preventative maintenance. Information was received from three companies and more information is needed.

Motion by Council Member Fletcher; supported by Mayor Pro Tem Kalman to table based on setting up a meeting with HRC to negotiate a better price.

Unanimous Vote: Ayes: 5 Nays: 0

Motion Carries

- **City Logo:** Mayor Ross suggested putting up temporary signs with TIFA's help to cover a third of the cost while the city continues to work on a logo.

Motion by Council Member Elsen; supported by Mayor Ross to table the signs for Keego Harbor and add it to the agenda for next month.

Unanimous Vote: Ayes: 5 Nays: 0

Motion Carries

Motion by Council Member Elsen; supported by Mayor Ross to amend the agenda to include tab 10, TIFA Fran Leaf Park Arch

Unanimous Vote: Ayes: 5 Nays: 0

Motion Carries

TIFA -Fran Leaf Park Arch

City Council would like to get three updated quotes. Jesse Stefani provided a quote and was in attendance to answer questions.

Motion by Council Member Fletcher; supported by Mayor Pro Tem Kalman to table this until there is more information and bids.

Unanimous Vote: Ayes: 5 Nays: 0

Motion Carries

TIGRIS Aquatic Contract

Resolution by Mayor Ross; supported by Council Member Elsen to approve the service agreement with TIGRIS not to exceed \$2,120.50 and allow City Manager Neeb to sign this contract on behalf of the City of Keego Harbor.

Roll Call: Fletcher yes, Streng yes, Ross yes, Kalman yes, Elsen yes.

Resolution Carries

2026 Tri-Party Program- RCOC, Oakland County Commissioner, The City of Keego Harbor

Resolution by Council Member Streng; supported by Mayor Ross to approve City Manager Neeb to allocate the FY2026 Tri-party program funding for the 2028 Cass Lake project.

Roll Call: Streng yes, Elsen yes, Ross yes, Fletcher yes, Kalman yes.

Resolution Carries

Resolution 26-05 Great Lakes Water Authority Amendment No. 5 to the Water Service Contract

The changes pertain to exhibits and most recent metering. There were no changes to the costs.

Resolution by Council Member Streng; supported by Council Member Elsen to approve Mayor Ross and City Manager Neeb to enter into Resolution 26-05 amendment number five to the water service contract between Great Lakes Water Authority and the City of Keego Harbor.

Roll Call: Ross yes, Kalman yes, Streng yes, Elsen yes, Fletcher yes.

Resolution Carries

City Social Media

Social media archiving is necessary to comply with laws like FOIA. City Council would like one additional quote which will be reviewed by the City Manager and the City Attorney. City Manager will manage the Facebook page.

Resolution by Council Member Fletcher; supported by Council Member Elsen authorizing Ms. Neeb to enter into contract with an archive company and solicit more bids, evaluate the bids and after consulting with the city attorney enter into a contract that shall not exceed \$4,188 annually.

Roll Call: Elsen yes, Kalman yes, Fletcher yes, Ross yes, Streng yes.

Resolution Carries

Televising City Council Meetings

Resolution by Council Member Streng; supported by Council Member Fletcher to approve authorizing the expense for televising city council meetings, payments to be made from the city's general fund

Roll Call: Fletcher yes, Streng yes, Ross yes, Kalman yes, Elsen yes.

Resolution Carries

Resolution 26-06 Planning Commission Recommendation

City Attorney Tony Chubb drafted the resolution to recommend a smaller number of members and to remove the council liaison as a voting member.

Resolution by Council Member Fletcher; supported by Council Member Elsen Resolution 26-06 as presented.

Roll Call: Streng yes, Elsen yes, Ross yes, Kalman yes, Fletcher yes.

Resolution Carries

Oakland County Treasurer Tax Foreclosure Prevention

Motion by Council Member Elsen; supported by Mayor Ross to approve, placing the Foreclosure Prevention letter from the Oakland County Treasurer office on file.

Unanimous Vote: Ayes: 5 Nays: 0

Resolution Carries

Resolution 26-08 Opposition to HB 5529

City Attorney Chubb reviewed the resolution in opposition to bills pertaining to the zoning and enabling act that will greatly limit the control over residential property setbacks and buildability.

Resolution by Council Member Elsen; supported by Council Member Streng to oppose certain Michigan House bills 5529, 5530, 5531, 5532 and House

bills 5581, 5582, 5583, 5584, 5585 as stated.

Roll Call: Kalman yes, Elsen yes, Ross yes, Fletcher yes, Streng yes.

Resolution Carries

Graduation Banner and Flags

Resolution by Council Member Elsen; supported by Council Member Fletcher annually we provide the cost to cover the flags for our graduating students in our community.

Roll Call: Streng yes, Fletcher yes, Elsen yes, Ross yes, Kalman yes.

Resolution Carries

The City Attorney requests a closed session pursuant to MCL 15.268(1)(h) to discuss an attorney-client privileged memorandum exempt from disclosure pursuant to MCL 15.243(1)(g).

Resolution by Mayor Pro Tem Kalman; supported by Council Member Elsen to go into closed session.

Roll Call: Fletcher yes, Elsen yes, Kalman yes, Streng yes, Ross yes.

Resolution Carries

Closed Session 9:12 pm

Open Session 9:26 pm

Motion by Mayor Pro Tem Kalman; supported by Council Member Fletcher to accept the settlement recommendation of the City Attorney and authorize City Manager Neeb to execute and release documents in a form approved by City Attorney.

Unanimous Vote Ayes: 5

Nays: 0

Motion Carries

COUNCIL COMMENTS

ADJOURNMENT

Mayor Ross adjourned the meeting at 9:38 pm.

Joel Ross
City of Keego Harbor, its Mayor

Stacy Goodall
City of Keego Harbor, its Deputy
Clerk



To: City Council
Date: April 16, 2026
Subject: TIFA -Fleis & Vandenbrink

BACKGROUND

- Developer Day
- Newsletter

RECOMMENDATION

Discussion



MEMO

To: Keego Harbor City Council

From: Samantha Mariuz, Economic Development Manager

Cc: Tammy Neeb, City Manager

Date: April 8, 2026

RE: **Keego Harbor Tax Increment Finance Authority (TIFA) Newsletter Initiative**

Introduction and Purpose

The purpose of this memorandum is to introduce and seek support for the development of a quarterly Keego Harbor TIFA Newsletter as part of a broader effort to strengthen communication, visibility, and engagement around the City's Tax Increment Finance Authority (TIFA). While TIFA serves as a valuable economic development tool, its function and impact are often not well understood by residents, business owners, and stakeholders who directly benefit from its investments. This initiative is intended to bridge that gap by clearly communicating how TIFA reinvests tax dollars back into the community to support infrastructure, business growth, and placemaking efforts.

Enhancing Visibility and Understanding

The newsletter will serve as a platform to highlight how captured tax increment revenues are being utilized within the district. By reinforcing the concept that TIFA does not increase taxes, but rather reinvests growth into the community, the City can build broader public understanding and support for ongoing and future initiatives. This is particularly important as Keego Harbor continues to position itself as a desirable destination for both residents and businesses.

Promoting Programs and Opportunities

In addition to education, the newsletter will actively promote available programs and opportunities, including the Façade Improvement Grant Program and other business support tools. Increasing awareness of these programs is critical to driving participation, ensuring that available resources are utilized, and maximizing the impact of TIFA investments along the corridor. By communicating eligibility, timing, and in the future, providing examples of completed improvements, the City can reduce barriers to participation and encourage property and business owners to take advantage of these resources.

A key component of the newsletter will be the inclusion of business spotlights, which will highlight local businesses, recognize recent investments, and reinforce the value of reinvestment within the district. TIFA has already identified three businesses to feature in initial editions, Buscemi's, Merchant of Vino, and 7 Stone, with plans to expand participation in future issues. These spotlights are intended to showcase real, local examples of success, build momentum, and encourage other businesses and property owners to engage with TIFA programs and contribute to the continued enhancement of the corridor.

MEMO



Distribution and Frequency

The intent is to produce the newsletter on a quarterly basis and distribute it through the City's existing Constant Contact email list, leveraging an established communication channel to efficiently reach residents, business owners, and community stakeholders. Over time, this consistent communication will help establish a stronger identity for the TIFA district, promote ongoing activity, and support a more coordinated approach to economic development and corridor enhancement.

Conclusion and Recommendation

Ultimately, this initiative is about visibility, transparency, and momentum. By clearly telling the story of how TIFA functions and the tangible benefits it delivers, the City can foster greater community alignment, encourage private investment, and reinforce the value of keeping tax dollars working locally. Support from City Council will be instrumental in advancing this effort and ensuring its success as part of Keego Harbor's broader economic development strategy.

Attachment: TIFA Newsletter Outline for Email Distribution through Constant Contact

KEEGO HARBOR

TAX INCREMENT FINANCE AUTHORITY

Business Spotlight

Business Q&A1

Business Q&A 2

Business Q&A 3

Why Keego?

Write up about why this business chooses to Keego Harbor and how the community has supported its success - quote from business owner here. Rotating Businesses in the TIFA District

Grant Opportunity

The Keego Harbor TIFA Façade Improvement Grant Program provides funding to help property and business owners improve storefronts, signage, and building exteriors. This is a great opportunity to enhance your space, attract more customers, and elevate your presence along the corridor. Join other local businesses in investing in Keego Harbor and help create a more vibrant and welcoming community.

[CLICK HERE TO APPLY TODAY](#)



FUELING LOCAL PROGRESS: INSIDE KEEGO HARBOR'S TIFA

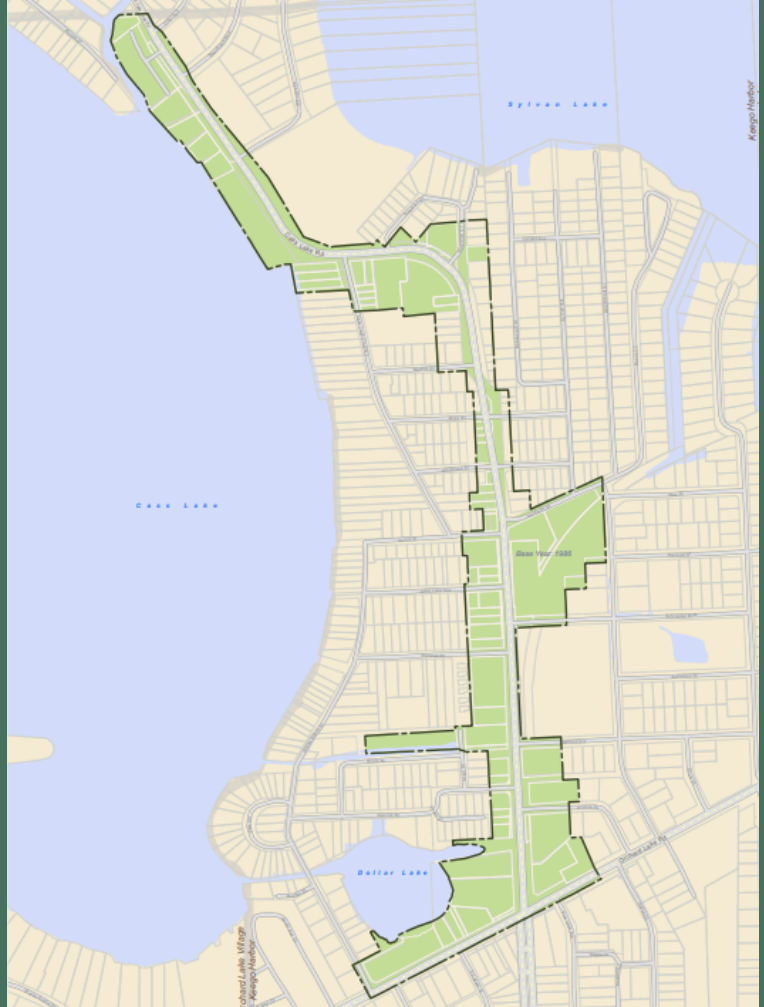

The Keego Harbor Tax Increment Finance Authority (TIFA), established under Michigan's Public Act 57 of 2018, is a local economic development tool designed to reinvest growth back into the community. As property values increase within the TIFA district, a portion of the new tax revenue is captured and directed toward public improvements such as streetscapes, infrastructure upgrades, façade enhancements, and business support programs. This allows Keego Harbor to strengthen its commercial corridor, attract private investment, and enhance the overall quality of place, ensuring long-term economic vitality for residents and businesses alike.

keegoharbor.org

Memorandum

To: Ms. Tammy Neeb, City Manager
From: John Balint/Logan Delonis
CC: Brad Shepler
Date: April 15, 2026
Subject: Remaining Budget for Water Quality Planning

HRC Job No. 20220262

In the City Council study session that took place yesterday, April 14th, 2026, HRC was asked to provide the remaining budget for water quality planning and assess which items we believe can fit within that budget. After some research we found that of the \$50,000 funding for water quality planning we have a remaining budget of \$24,021.91, which we believe should be enough to implement all proposed water quality improvements that we discussed in the meeting. There is also a strong possibility that the other projects that fall under the same Critical Infrastructure Grant will not need the full amount allocated to them, which we could then use if there is any issue with remaining funding. Below is a breakdown of the estimated cost to implement each measure discussed:

- Ordinance Updates - \$17,000
- Public Education Newsletters - \$2,000
- New Schematics for Ditches and Ditch Enclosures - \$2,000
- Water Quality Sampling - \$3,000

The total estimated cost to implement all proposed measures is estimated to be around \$24,000, which is what our budget is currently set at. As we also stated in the meeting, we do not foresee any issues with the budget, but should any problems arise, our priority would be to implement the ordinance updates first. However, we believe that we have the resources necessary to enact all proposed changes, and with council's approval we will start working towards that.

Contacts:

Keego Harbor

Tammy Neeb(City Manager/City Clerk)
manager@keegoharbor.org

Hubbell, Roth & Clark, Inc.

Brad Shepler, P.E. (Senior Associate)
bshepler@hrcenr.com



MAILING: PO Box 824
 Bloomfield Hills, MI 48303-0824
SHIPPING: 555 Hulet Drive
 Bloomfield Hills, MI 48302-0360
PHONE: 248-454-6300
WEBSITE: hrcengr.com

Memorandum

To: Ms. Tammy Neeb, City Manager
From: John Balint/Logan Delonis
CC: Brad Shepler
Date: April 9, 2026
Subject: Proposed Initiatives Stemming from the Water Quality Planning Project HRC Job No. 20220262

The following is a summary of the proposed initiatives stemming from the Keego Harbor Water Quality Planning project, specifically related to planning and ordinance revisions for the lakes, storm water and drainage systems, and wetlands. This project is funded through the Oakland County Local Government Critical Infrastructure Grant which will be expiring September 15, 2026. Keego Harbor understands that water quality of nearby lakes and watersheds are of the utmost importance. Due to the lakefront nature of the community, understanding what pollutants are of concern within Keego Harbor and surrounding communities and determining how the City can reduce or eliminate these pollutants is a goal of this project.

Executive Summary:

The Keego Harbor Water Quality Planning project was started to help identify ways that the City can improve the water quality of its surrounding lakes, wetlands, and other waterways. HRC reviewed existing ordinances, MS4 documents, and ordinances from similar lakefront communities to find ways to improve guidelines set forth to protect water quality. Through these reviews we found several initiatives we thought could be effective. Through this effort, we created a document that was then discussed with the City for their input. The outcome of that meeting provided the following initiatives:

- Update ordinances to require all new non-single family residential developments (regardless of size) to include water quality improvements such as raingardens, swales, mechanical filters, or other stormwater infrastructure the fits the proposed use.
- Update ordinances to eliminate direct discharge into lakes by requiring the water go through a sump, mechanical filter, or green space, etc. prior to discharging.
- Applying infiltration standards from Oakland County that currently apply to sites over 1 acre to all non-single family residential sites regardless of size
- Increase public education on water quality by sending out newsletters to residents regarding existing ordinance related stormwater management items like the 15' fertilizer buffer from shorelines and other water quality issues
- Develop schematics for ROW ditches and ditch enclosures to be used in future projects
- Coordinate with the County to conduct water quality sampling at discharge locations
- Stricter enforcement of ROW permitting

With this list of initiatives now created we would like council's input and approval to begin implementation. The money already provided in the Water Quality Planning grant that was approved by the Council on April 18, 2024 is available for us to move forward with these initiatives once approved, we will go through the processes of implementing these changes by writing new ordinances and updating existing ones, creating newsletters for residents, developing the ditch

<p>Delhi Township 2101 Aurelius Rd. Suite 2A Holt, MI 48842 517-694-7760</p>	<p>Detroit 535 Griswold St. Buhl Building, Ste 1650 Detroit, MI 48226 313-965-3330</p>	<p>Grand Rapids 81925 Breton Road SE Suite 100 Grand Rapids, MI 49506 616-454-4286</p>	<p>Howell 105 W. Grand River Howell, MI 48843 517-552-9199</p>	<p>Jackson 401 S. Mechanic St. Suite B Jackson, MI 49201 517-292-1295</p>	<p>Kalamazoo 834 King Highway Suite 107 Kalamazoo, MI 49001 269-665-2005</p>	<p>Lansing 215 S. Washington SQ Suite D Lansing, MI 48933 517-292-1488</p>
---	---	---	--	--	---	---

schematics, and contacting the county to coordinate water quality sampling.

Methods and Strategies:

The proposed initiatives would require the following:

- 1) Ordinance Updates – In order to implement the proposed ordinance changes relating to water quality improvements for all new non-single family homes, direct discharge into lakes, applying infiltration standards to all non-single family residential sites, and ROW enforcement HRC would develop new ordinances and update existing ones to comply.
- 2) Public Education – There are existing ordinances that are aimed toward water quality improvement such as the 15' fertilizer buffer from shorelines, keeping the watercourses free of trash, and a ban on coal tar sealants. HRC would assist in the development of a newsletter to increase awareness of these existing guidelines. This newsletter could then be continued, with the assistance of HRC to promote public education related to stormwater and serve as a public education benefit for the City's MS4 permit.
- 3) New schematics for ROW ditches and ditch enclosures – HRC would create schematics for ditches that would then be included in all future projects that either repair existing ditches and ditch enclosures or create new ones.
- 4) Water Quality Sampling – HRC would contact the county to coordinate water quality sampling at county discharge locations

Desired Outcomes:

We believe that the proposed initiatives should improve the City's water quality in the following ways:

- 1) Ordinance Updates – The ordinance changes would require that new or renovations to non-single family residences:
 - a) Install water quality improvements prior to discharging stormwater
 - b) Comply with Oakland County Infiltration Standards that currently apply to sites over 1 acre
 - c) Are barred from directly discharging stormwater into waterways regardless of size or zoning of the site

These measures would clean the stormwater prior to being discharged into waterways or storm sewers and prevent stormwater from entering sewers or waterways by infiltrating it into the soil. This would increase the quality of the water entering waterways as well as decrease the volume of stormwater and overall decrease the number of pollutants entering Keego Harbor's waterways.

- 2) Public Education – By reminding residents of existing ordinances aimed at increasing water quality, we hope to educate them on why these measures are important. Public education raises awareness of the problem, can drive behavior change and encourage community involvement, all of which can be a "first line of defense" against pollution.
- 3) New Schematics for ROW ditches and ditch enclosures – By developing these schematics we would standardize this aspect of storm water management for new projects effecting the ROW of the City. This would increase quality by promoting infiltration and use of green space to "clean" the water prior to it entering the storm sewers or waterways.
- 4) Water Quality Sampling – Water quality sampling at County discharge locations would help to identify harmful pollutants that may be unknowingly entering Keego Harbor's waterways. Identifying these pollutants could help to locate where these pollutants are coming from and possibly eliminate them.

Schedule:

All proposed work shall be completed on or before September 15, 2026, in accordance with the expiration of the Critical Infrastructure Grant.

Contacts:

Keego Harbor

Tammy Neeb(City Manager/City Clerk)

manager@keegoharbor.org

Hubbell, Roth & Clark, Inc.

Brad Shepler, P.E. (Senior Associate)

bshepler@hrcenr.com

Evaluate existing ordinance

- ≡ MS4 Documents:
 - a. Existing water quality related ordinances: [Chapter 16 - ENVIRONMENT AND NATURAL RESOURCES | Code of Ordinances | Keego Harbor, MI | Municode Library](#)
 - b. SWMP Packet - [swmp_reference_packet.pdf](#)
 - i. Goals
 1. Educate the public of storm water
 2. Bi-yearly meetings with stakeholder groups (local governments, business, and citizens) on the City's proposed storm water management program.
 3. A comprehensive map of storm drains to identify and remove illicit discharge, establish legal authority for enforcement actions, and encourage public education and involvement in eliminating illicit discharge
 4. ESC requirement for construction sites that disturb >5000 Sqft
 5. Reduce directly connected impervious surfaces in new developments and maintain structure storm water controls.
 6. List of BMPS with location and site conditions compiled
 - ii. IDEP procedures, training, and evaluation
 - iii. Structural storm water operation and maintenance activities
 - iv. ERP
- ≡ TMDL Info: [Total Maximum Daily Loads \(TMDLs\)](#)
 - Pollutant: E.Coli - [Statewide E. coli TMDL 2019](#)
 - Pollutant under evaluation: PCB found in fish tissue in Cass lake - [2024 Statewide PCB TMDL Addenda - Additions Appendix A \(XLSX\)](#), [Statewide PCB Total Maximum Daily Load \(TMDL\) Addendum – 2024](#)

Review and Study: Keego Harbor and Surrounding Communities

	Community			
	Keego Harbor	Sylvan Lake	West Bloomfield	Waterford Twp
Ordinances	Environmental and Natural Resources	Environment	Stormwater Management	Environment Protection
Plans				
BMP's				
Wetland Management	<p>-Fran Leaf Park wetland restoration project: remove invasive species, remove past infilling, restore wet meadow plants, build raise walkway, install educational signage</p> <p>- Recreation Master Plan</p>			
Water Quality Data	<p>- Annual Consumer Confidence Report</p> <p>- Cass lake tested for E.Coli and monitored during summer months</p> <p>- Shoreline of Cass lake impacting natural habitats and water quality</p>			
Land Use (SEMCOG)	43% impervious, 28% open space, 13% water, 47% residential areas	26% impervious, 40% water, 18% open space, 33% residential areas.	23% impervious, 33% trees, 26% open space, 16% water, 49% residential areas.	26% impervious, 28% trees, 30% open space, 15% water, 42% residential area.

Develop:

- ≡ Improved Ordinances
- ≡ MS4 Improvements
 - Current Projects
 - Sewer System Improvement FY24 CWSRF Project Plan
 - Stormwater Infrastructure Improvement Grant Application
 - Water Reliability Study and Water Assets Management Plan Update
 - Sewer Investigation and Asset Management Plan Update
 - BMPs/Green Infrastructure
 - Bioretention Cells – filter out pollutants from runoff before infiltration into the ground
 - Increase permeable pavements

- Vegetated swales – slow water flow
 - Detention/Retention basins – store stormwater to allow pollutants to settle
 - Constructed wetlands – treat stormwater by allowing sediment and pollutants to settle and plants absorb contaminants
 - Green roofs – absorb rainfall and reduce runoff
 - Street sweeping – removal of debris before entering the storm drains
 - Pet waste management
 - Illicit discharge programs – identify and eliminate illegal dumping into stormwater systems
 - Public education on proper disposal of hazardous materials
 - SESC measures during construction
 - Proper fertilization to reduce Nitrogen and phosphorus runoff and maintain buffer zones along shorelines
 - Native vegetation landscaping
 - Regular inspections of septic systems
 - Use of Brine instead of rock salt for snow and ice management (See below for more details)
 - Shoreline erosion control methods (i.e., toe wood, riprap, vegetation)
- ≡ Natural Feature Mapping
 - ≡ Natural Feature Setbacks Rules/Ordinances
 - Typical Requirements
 - Ann Arbor Example - [Section _____ Natural Feature Setback](#)
 - Other Examples : [Natural Features Setback | Michigan Lakes & Streams Association, INC](#)
- ≡ Residential and Commercial Shoreline Improvements
 - Lake front properties
 - Public education about water quality
 - Ordinances against certain pesticides
 - Lake Charter Meetings that discuss water quality improvements
 - Michigan Shoreland Stewards Program (recognizing lakefront property owners that reduce negative impacts on the lake)
 - Requirements for the development of new lakefront homes
 - Residential Improvements
 - Native plant buffers to stabilize soil and filter runoff
 - Avoid excessive use of fertilizers and pesticides and establish a no mow zone (at least 10-15ft wide)
 - Rain gardens and bioswales to capture and filter stormwater

- Use permeable surfaces
 - Bioengineering shoreline stabilization
 - Floating/seasonal docks – minimize shoreline disturbance
- Commercial Improvements
 - Living shorelines (vegetation only, edging, sills)
 - Riprap and reinforced slopes (large rocks)
 - Retention ponds
 - Green infrastructure and permeable surfaces
 - Public access boardwalks and floating walkways
 - Convert degraded shorelines to functional wetlands that absorb stormwater and filter pollutants
 - Signage to educate the public about shoreline protection
- ≡ Water Quality Improvement
 - Brine vs Salt during winter road operations
 - Salt can contaminate aquatic life. By using a brine, the amount of salt that is needed is reduced and in turn reduced water contamination from runoff and saves money
 - Salt applied to roadways during the winter months can leach into bodies of water when snow melts begin. Brines stick to where they are places and are not subjected to moving around like rock salt
 - 1 tsp of salt can pollute up to five gallons of water
 - Brine can prevent snow/ice from adhering to pavement surfaces if applied before a storm for easy removal. Additionally, it works quicker than salt as it accelerates the process after the salt becomes a brine before effectively working on surfaces.
 - Cons:
 - Initial setup cost for brine production equipment
 - Storage challenges due to liquid form
 - Less effective at temperatures before 15 degree F
 - Pros:
 - Faster melting action due to liquid form
 - Reduces overall salt usage, minimizing environmental impacts
 - Lower yearly costs
 - Country Drains
 - Coordinate with County to conduct water quality sampling at county discharge locations
 - Follow county regulations



To: City Council

Date: April 16, 2026

Subject: City Hall Copier

BACKGROUND

City hall has owned the current administration copier for 6 years with a service contract that ends June 1, 2026. A 30-day written notice is required to terminate the auto renewal. A cost analysis of usage is included in the packet. City staff had a chance to test run the copier at Applied Innovation's warehouse. Applied Innovation has provided excellent customer service.

Applied Innovation- Ricoh C4510SD (12'X18" scanner)

- Monthly lease and services: \$257.24
- Toner and supplies included
- 45 copies per minute
- BW Copies: \$0.009 (charged over 3,000)
- Color Copies: \$ 0.058 (charged over 1,000)

Applied Innovation- Ricoh C3510SD (12"x18" scanner)

- Monthly lease and services: \$245.76
- Toner and supplies included
- 35 copies per minute
- BW Copies: \$0.009 (charged over 3,000)
- Color Copies: \$ 0.058 (charged over 1,000)

Toshiba- E-Studio 3525AC

- Monthly lease \$248.48
- Toner and supplies included
- 35 copies per minute
- BW Copies (charged over 3,900)
- Color Copies (charged over 1,200)

RECOMMENDATION

Resolution to approve (or deny) City Manager Neeb terminating the service contract with Millennium and enter into a new contract with Applied Innovations for a 60-month lease of a new copier, not to exceed \$257.24.

FY2425 Budget: \$1,500; total spent was under budget at \$1,432.16 including toner replacements/waste toner cartridges at \$15 each.

- B/W allotment(Admin & PD): 3,900/month
- Color allotment: 1,200/month
- Overage rates:
 - B/W: \$0.00931
 - Color: \$0.05929

Monthly Summary

Month	Admin Totals	PD Totals	B/W Overage	B/W Cost	Admin Color Totals	Color Overage	Color Cost
1	3130	260	0	\$0.00	1097	0	\$0.00
2	2325	176	0	\$0.00	1082	0	\$0.00
3	2876	724	0	\$0.00	1667	467	\$27.69
4	2398	676	0	\$0.00	1201	1	\$0.06
5	3396	472	0	\$0.00	1091	0	\$0.00
6	3498	707	305	\$2.84	1476	276	\$16.36
7	1448	1071	0	\$0.00	1319	119	\$7.06
8	2942	862	0	\$0.00	2155	955	\$56.62
9	3575	657	332	\$3.90	782	0	\$0.00
10	3481	525	106	\$0.99	1529	329	\$19.51
11	3343	697	140	\$1.30	1145	0	\$0.00
12	3343	679	122	\$1.14	962	0	\$0.00
Total:	35,755	7,506	1,005	\$10.17	15,506	2,147	\$127.30

Monthly Totals

Black & White

- Total overage copies: 1,005
- Total cost: \$10.17

Color

- Total overage copies: 2,147
- Total cost: \$127.30

Combined Annual Overage Cost

Category	Cost
B/W	\$10.17
Color	\$127.30
Total	\$137.47

Total annual overage cost is relatively low and under overall budget.

Color Overage is concentrated in a few months

High-cost months:

- Month 8: **\$56.62** (New computers proposals, carports)
- Month 3: **\$27.69**
- Month 10: **\$19.51**

B/W usage is well controlled

- Only 5 months exceeded the B/W allotment
- Even then, costs remained very low

Note: Boards/Commission Packets (21,601 pages)

Annual Copy Usage vs Allotment (2025)

Category	Allotted	Actual Usage Including PD B/W	Overage / (Under)
Black & White	46,800	43,261	(3,539) <i>(under)</i>
Color	14,400	15,506	1,106

April 9, 2026

City of Keego Harbor

Proposed Device:

(1) Ricoh IM C4510SD

Monthly Service: (3,000 BW & 1,000 color pages)

-BW cost per copy: \$0.009

-Color cost per copy: \$0.058

-45 B&W & Color pages per minute

-Includes (4) 550 sheet paper tray

-Staple Finisher and hole punch

-Includes Delivery, Setup, and installation

-Includes all Toner, Parts, Labor, and Service

-Includes workstation connectivity and training

60-month Lease FMV with service	\$257.24
Purchase Price	\$8,313.25
Estimated Service	\$69.34

Southfield Office

24050 Northwestern Hwy

Southfield, MI 48075

Tel: 248-473-6300

www.appliedinnovation.com



April 9, 2026

City of Keego Harbor

Proposed Device:

(1) Ricoh IM C4510SD



Southfield Office

24050 Northwestern Hwy

Southfield, MI 48075

Tel: 248-473-6300

www.appliedinnovation.com



April 9, 2026

City of Keego Harbor

Proposed Device:

(1) Ricoh IM C3510SD

Monthly Service: (3,000 BW & 1,000 color pages)

- BW cost per copy: \$0.009*
- Color cost per copy: \$0.058*
- 35 B&W & Color pages per minute*
- Includes (4) 550 sheet paper tray*
- Staple Finisher and hole punch*
- Includes Delivery, Setup, and installation*
- Includes all Toner, Parts, Labor, and Service***
- Includes workstation connectivity and training*

60-month Lease FMV with service	\$245.76
1 machine- Purchase Price	\$7,672.54
Estimated Service	\$79.70

Southfield Office

24050 Northwestern Hwy

Southfield, MI 48075

Tel: 248-473-6300

www.appliedinnovation.com



April 9, 2026

City of Keego Harbor

Proposed Device:

(1) Ricoh IM C3510SD



Southfield Office

24050 Northwestern Hwy

Southfield, MI 48075

Tel: 248-473-6300

www.appliedinnovation.com



April 9, 2026

City of Keego Harbor

Proposed Device:

(1) Ricoh IM C4510SD

Monthly Service: (3,000 BW & 1,200 color pages)

- BW cost per copy: \$0.009*
- Color cost per copy: \$0.058*
- 45 B&W & Color pages per minute*
- Includes (4) 550 sheet paper tray*
- Staple Finisher and hole punch*
- Includes Delivery, Setup, and installation*
- Includes all Toner, Parts, Labor, and Service***
- Includes workstation connectivity and training*

60-month Lease FMV with service	\$283.63
Purchase Price	\$8,313.25
Estimated Service	\$69.34

Southfield Office

24050 Northwestern Hwy

Southfield, MI 48075

Tel: 248-473-6300

www.appliedinnovation.com



April 9, 2026

City of Keego Harbor

Proposed Device:

(1) Ricoh IM C4510SD



Southfield Office

24050 Northwestern Hwy

Southfield, MI 48075

Tel: 248-473-6300

www.appliedinnovation.com



April 9, 2026

City of Keego Harbor

Proposed Device:

(1) Ricoh IM C3510SD

Monthly Service: (3,000 BW & 1,200 color pages)

-BW cost per copy: \$0.009

-Color cost per copy: \$0.058

-35 B&W & Color pages per minute

-Includes (4) 550 sheet paper tray

-Staple Finisher and hole punch

-Includes Delivery, Setup, and installation

-Includes all Toner, Parts, Labor, and Service

-Includes workstation connectivity and training

60-month Lease FMV with service	\$254.71
1 machine- Purchase Price	\$7,672.54
Estimated Service	\$79.70

Southfield Office

24050 Northwestern Hwy

Southfield, MI 48075

Tel: 248-473-6300

www.appliedinnovation.com



April 9, 2026

City of Keego Harbor

Proposed Device:

(1) Ricoh IM C3510SD



Southfield Office

24050 Northwestern Hwy

Southfield, MI 48075

Tel: 248-473-6300

www.appliedinnovation.com



INVESTMENT SCHEDULE

City of Keego Harbor

Proposed Solution

Model Details

- (1) Toshiba e-STUDIO3525ACG
 - Included Features: DSDF Document Feeder, Large Capacity Feeder, 65-sheet Multi-Staple Finisher, Bridge Kit, Fax Unit / 2nd Line Fax Unit

Service Details

Pool Name	Pool Type	Monthly Pages Included	Quarterly Overage Per Page
Mono Copier Pool	Mono	3,900	\$0.00900
Color Copier Pool	Color	1,200	\$0.05000

Total Monthly Investment

\$248.48

Monthly investment includes parts, labor, travel, and supplies; everything except for paper, staples, shipping of supplies, one-time documentation fees, and applicable taxes.

MBS

Millennium Business Systems
 33140 Industrial Rd.
 Livonia, MI 48150
 734-591-3100 Fax: 734-591-9120
 734-591-3101

Maintenance Agreement

BILL TO:		EQUIPMENT LOCATION:	
Name	City of Keego Harbor	Name	Same
Address	2025 Beechmont Street	Address	
City/State/Zip	Keego Harbor, MI, 48320	City/State/Zip	
Telephone	248-682-1930	Telephone	
Contact	Lori Gilman	Contact	

Coverage From 6/1/23 – 6/1/25

Manufacturer	Model	ID #	Serial #	Beginning Meter
Xerox	Altalink 8035/H2	12470	3TX408829	
Toshiba	E-Studio 257 B/W	12078	CEFE20798	

MBS shall provide to you all repair services, drums, developer and parts necessary for the Equipment listed to operate in good working order and black toner as indicated below. Color Toner may not be included in this agreement. Toner & imaging units are not included on FAX, Printer or Wide Format Copier agreements. Network related service calls are not covered by this Agreement. Network service maintenance agreements are available.

The term of this Agreement shall be effective on the date of original installation of the Equipment (or the date of expiration of your current Maintenance Agreement, if applicable). The first invoice and shipment will represent the entire annual commitment. Subsequent invoices will be issued when time or copies have expired.

Toner will be shipped at the request of the Customer.

Other Terms or Conditions:

\$44 for 3900 B&W copies, with additional copies \$.00931 \$60 for 1200 color copies, with additional copies \$.05929
--

This Agreement is written in 'Plain English'. The words you and your, refer to the Customer. The words owner, we, us, our, and MBS refer to Millennium Business Systems.

I have read and agree to the terms and conditions of coverage under this Maintenance Agreement. These conditions constitute the entire understanding between Millennium Business Systems and me and no other written or oral representation by any party shall be binding upon Millennium Business Systems.

Customer Acceptance:

By: Tammy Neeb Date 6/29/2023

Millennium Business Systems Acceptance:

President: [Signature] Date _____

Terms of Agreement

This Maintenance Agreement (Agreement) will become effective when Millennium Business Systems (MBS) receives payment for the Agreement charges shown on the front of this Agreement. The Agreement will be in effect for the coverage shown, and will automatically renew for a twelve (12) month term, unless you send us written notice thirty days before the end of the term that you do not want the Agreement to renew. At any anniversary date, pricing is subject to change. MBS may cancel the automatic renewal terms by notifying you, in writing, that we do not want the Agreement to renew. You may cancel this Agreement by sending us written notification and by prepaying 80% of the remaining monthly minimum charges that are shown on the front of this Agreement.

Taxes

You agree to pay when due, all taxes, where applicable, relating to this Agreement.

Payments and Servicing

You agree to make payments for the Agreement according to the payment schedule shown on the front of this Agreement. MBS agrees to provide parts and servicing for the Equipment shown on this Agreement according to the terms and conditions of the Agreement. If you do not pay your payments when due, you agree that MBS will have no obligation to service the equipment during the time when payments are not current. You also agree that if the Agreement provides maintenance and parts for MBS leased equipment, and if the lease is in default, MBS will have no obligation to service the Equipment, even though payments may be current on the Agreement. You understand and agree that if MBS is called upon to perform service on the Equipment under contract and the Agreement is discovered to have expired, either by meter reading or date, you may either renew the Agreement as of the expiration meter reading or date, whichever occurred first, or pay for the service rendered. If service is completed after the expiration meter reading or date, it will be at current labor and parts rates. All prices do not include cost of freight. You are responsible for all freight charges on supplies.

Toner Usage

The yields represent 100% of manufacturer's stated yields based on standard "letter size" copies with 6% coverage for both color and black and white machines. You may be billed for any toner used in excess of these yields. Toner for faxes, printers, color machines and wide format machines may not be included.

Late Charges

If any part of your payment is more than fifteen (15) days late, you agree to pay a late charge of 1.5% per month on any unpaid amounts.

Maintenance and Supplies

The charges established by this Agreement include payment for the use of the designated Equipment and accessories, maintenance (during normal business hours); inspection, adjustment, parts, replacement drums and cleaning material required for the property operation as well as black toner and developer. Maintenance and supplies for printers and fax machines may not be included. All other maintenance and supplies are specifically excluded. Paper, staples, color toner, freight, fuel, and trip charges are additional charges. If necessary, the service and supply portion of the Agreement may be assigned. The stated yields represent 100% of manufacturer's stated yields based on standard "letter size" copies with 6% coverage. At the end of each billing cycle, you may be billed for any toner used in excess of that required based on yields stated above. Any and all parts that are discontinued by the manufacturer are not covered. Electronic circuit boards and networking are **NOT** our responsibility. Improper usage of the Equipment will immediately void our obligation to provide maintenance and you will be required to pay for all maintenance and repairs at our customary service and parts rates in addition to the Agreement payments. Improper usage includes, but is not limited to: 1) Failure to comply with the Equipment manufacturer's operating instructions. 2) Service of the Equipment by anyone other than our authorized service technicians. 3) Use of supplies or parts not obtained from us. 4) Damage caused by any act of yours, your agents or your employees. There are no set-offs if the equipment is not working.

Warranty Disclaimer

We disclaim all warranties in connection with the assets, expressed or implied, as to any matter whatsoever, including without limitation, description, quality, design, performance, specifications, condition, merchantability, and fitness for any particular purpose except as expressly set forth in this Agreement. The Equipment covered by this Agreement are "as is" and "with all faults". You are assigned all warranties of the manufacture, if any, according to the manufacturer's warranty terms and shall at all times remain, the sole and exclusive property of us; you shall have no right, title or interest in it except as expressly set forth in this Agreement.

Location of Equipment

You will keep and use the Equipment only at your address shown on the front of this Agreement and you agree not to move it unless we agree to it.

Indemnity

We are not responsible for any loss or injuries caused by the installation or use of the Equipment. You agree to hold us harmless from any claim and shall pay all costs and actual attorney fees in defending any action.

Service and Preventative Maintenance Calls

Service calls will be performed during our normal business hours, unless agreed upon in advance that service will be performed by MBS at after business hours rates. Preventative maintenance may be performed in conjunction with regular emergency service calls.

Protective Devices

MBS may, at its option, and at times, at its own expense, find it necessary to install protective devices, such as surge protectors, for the Equipment. These protective devices will remain the property of MBS and must be returned promptly upon termination of this Agreement. If not returned to us within fifteen (15) days, and upon receipt of an invoice from MBS, you agree to purchase any installed protective devices at a fair market value.

Default

If you do not pay Agreement payments when due or if you break any promises to this Agreement, you will be in default. If you default, we can declare the Agreement terminated and proceed against you for unpaid invoices. If we refer this Agreement to an attorney you agree to pay reasonable attorney's fees and actual costs.



TO: City Council

DATE: April 16, 2026

SUBJECT: Resolution 26-10 West Nile Virus Prevention

BACKGROUND:

Oakland County administers a West Nile Virus Prevention Program that reimburses cities, villages, and townships for activities related to mosquito control and protection.

The city purchased wipes totaling \$275.64, with full reimbursement of that amount provided by Oakland County. Attached Resolution 26-10 authorizes the reimbursement request, as required by the County's program. The city has participated in this program for many years, and residents value the free products available to them at City Hall.

RECOMMENDATION:

Resolution to approve Resolution 26-10 Authorizing West Nile Virus Prevention Program Reimbursement Request as presented.

CITY OF KEEGO HARBOR

COUNTY OF OAKLAND, MICHIGAN

RESOLUTION 26-10
AUTHORIZING REIMBURSEMENT REQUEST
FOR WEST NILE VIRUS PREVENTION REIMBURSEMENT PROGRAM

Minutes of a Meeting of the City Council of the City of Keego Harbor, County of Oakland, Michigan, held in the City Hall of said City on April 16, 2026, at 7 o'clock P.M.

The following Resolution was offered by _____ and supported by _____.

WHEREAS; the Oakland County Board of Commissioners has established a West Nile Virus Fund Program to assist Oakland County cities, villages, and townships in addressing mosquito control activities; and,

WHEREAS; Oakland County's West Nile Virus Fund Program authorizes Oakland County cities, villages, and townships to apply for reimbursement of expenses incurred in connection with mosquito protection activities; and,

WHEREAS; the City of Keego Harbor has incurred expenses in connection with mosquito protection activities; and,

WHEREAS; the City of Keego Harbor is eligible for reimbursement under Oakland County's West Nile Virus Fund Program

NOW, THEREFORE, BE IT RESOLVED, that the Keego Harbor City Council authorizes the City Manager, as agent for the City of Keego Harbor, to request reimbursement for mosquito control activities under Oakland County's West Nile Virus Fund Program.

AYES:

NAYS:

CERTIFICATION

I hereby certify that the foregoing is a true and complete copy of a resolution adopted by the City Council of the City of Keego Harbor, County of Oakland, and State of Michigan, at a regular meeting held April 16, 2026, and that public notice of said meeting was given pursuant to and in full compliance with Act No. 267, Public Acts of Michigan, 197 6, and that the minutes of said meeting have been kept and made available to the public as required by said Act.2.

Tammy Neeb
City of Keego Harbor, its City Manager / City Clerk



To: City Council

Date: April 16, 2026

Subject: Council Member Liaison Appointment

BACKGROUND

Council Member Streng has expressed interest in serving as the City Council liaison to the TIFA Board and has reached out to both the City Manager and Mayor Ross regarding the appointment. Currently, the liaison position for TIFA has not been filled.

RECOMMENDATION

Motion to approve (or deny) City Council appoint Council Member Streng as the City Council Liaison to the TIFA Board.



To: City Council

Date: April 16, 2026

Subject: Orchard Lake Fine Art Show Banner

BACKGROUND

The Orchard Lake Fine Arts Show would like to display a banner across Orchard Lake Road at Maddy Lane from Wednesday, July 8, 2026, to Monday, July 27, 2026. The dates of the Orchard Lake Fine Art Show are Saturday, July 25th, and Sunday, July 26, 2025.

Please see the attached sign permit application and photo of the banner. The application has been sent to the Road Commission. Insurance paperwork is on file.

This permit is submitted and approved each year by the City Council

RECOMMENDATION

Consent Agenda

PAID

JAN 20 2026

CITY OF KEEGO HARBOR



"Heart of the Lakes"

City of Keego Harbor

2025 Beechmont

Keego Harbor MI 48320

SIGN PERMIT APPLICATION

Date: 1-5-2026

36-00-00-000-001

Permit No. PS 260001

12380

The undersigned applies for a permit to erect or alter a sign under the provisions of the Zoning Ordinance, according to the following statements:

Applicant/Contractor Hot Works Orchard Lake Fine Art Show

Phone 248-762-2462

Address PO Box 79, Milford, MI 48381-0079

Sign location Across Orchard Lake Rd side of building/road

Address At Maddy Lane

Owner Patty Narozny

Phone 248-762-2462

Distance from grade

Size of sign 4'x50' netted banner - see photo attached

Square Feet of sign 200'

Before any permit is granted for erection of a sign, the following requirements must be met:

1. The Business must be registered with the City and all Fire Department Regulations met.

2. Plans and specifications shall be filed with the Building Official showing the dimensions, materials and required details of construction including loads, stresses and anchorage, and distance from property lines.
3. Submit copy of liability insurance certificate with application.
4. A written consent of the owner or lessee of the premises upon which the sign is to be erected.
5. Obtain electrical permit prior to installation of sign.
6. Site Plan and/or Building Elevation where sign to be installed.

P. Harozny EV Hot Works, LLC 1-5-2026
Signature of Applicant/Contractor

Department of Planning

Zoning Approval: _____

Permit Fee: \$125.00 (Planner)

Department of Building Safety

Building Approval: _____

Inspection: \$ _____

Building Department Plan Review Fee: \$ _____

Bond: \$ _____

Contractor Registration: \$ _____

Total Due: \$ _____

Permit expires 1 year from date of issue, Permit Renewal fee is \$50.00



CERTIFICATE OF LIABILITY INSURANCE

DATE (MM/DD/YYYY)

01/13/2026

THIS CERTIFICATE IS ISSUED AS A MATTER OF INFORMATION ONLY AND CONFERS NO RIGHTS UPON THE CERTIFICATE HOLDER. THIS CERTIFICATE DOES NOT AFFIRMATIVELY OR NEGATIVELY AMEND, EXTEND OR ALTER THE COVERAGE AFFORDED BY THE POLICIES BELOW. THIS CERTIFICATE OF INSURANCE DOES NOT CONSTITUTE A CONTRACT BETWEEN THE ISSUING INSURER(S), AUTHORIZED REPRESENTATIVE OR PRODUCER, AND THE CERTIFICATE HOLDER.

IMPORTANT: If the certificate holder is an ADDITIONAL INSURED, the policy(ies) must have ADDITIONAL INSURED provisions or be endorsed. If SUBROGATION IS WAIVED, subject to the terms and conditions of the policy, certain policies may require an endorsement. A statement on this certificate does not confer rights to the certificate holder in lieu of such endorsement(s).

PRODUCER		CONTACT NAME: Victor Perez-Ruiz	
Caley Insurance		PHONE (A/C, No, Ext): (305) 800-2985 Ext. 106	FAX (A/C, No): (305) 603-8263
12260 Sw 8th St SUITE # 122		E-MAIL ADDRESS: victor@caleyinsurance.com	
Miami FL 33184		INSURER(S) AFFORDING COVERAGE	
		INSURER A: Nautilus Insurance Company	
		NAIC # 17370	
INSURED		INSURER B:	
Hot Works, LLC		INSURER C:	
PO Box 1425		INSURER D:	
Sarasota FL 34230		INSURER E:	
		INSURER F:	

COVERAGES**CERTIFICATE NUMBER:****REVISION NUMBER:**

THIS IS TO CERTIFY THAT THE POLICIES OF INSURANCE LISTED BELOW HAVE BEEN ISSUED TO THE INSURED NAMED ABOVE FOR THE POLICY PERIOD INDICATED. NOTWITHSTANDING ANY REQUIREMENT, TERM OR CONDITION OF ANY CONTRACT OR OTHER DOCUMENT WITH RESPECT TO WHICH THIS CERTIFICATE MAY BE ISSUED OR MAY PERTAIN, THE INSURANCE AFFORDED BY THE POLICIES DESCRIBED HEREIN IS SUBJECT TO ALL THE TERMS, EXCLUSIONS AND CONDITIONS OF SUCH POLICIES. LIMITS SHOWN MAY HAVE BEEN REDUCED BY PAID CLAIMS.

INSR LTR	TYPE OF INSURANCE	ADDL INSD	SUBR WVD	POLICY NUMBER	POLICY EFF (MM/DD/YYYY)	POLICY EXP (MM/DD/YYYY)	LIMITS
A	<input checked="" type="checkbox"/> COMMERCIAL GENERAL LIABILITY <input type="checkbox"/> CLAIMS-MADE <input checked="" type="checkbox"/> OCCUR GEN'L AGGREGATE LIMIT APPLIES PER: <input checked="" type="checkbox"/> POLICY <input type="checkbox"/> PRO-JECT <input type="checkbox"/> LOC OTHER:		X	NN1919882	10/30/2025	10/30/2026	EACH OCCURRENCE \$ 1,000,000 DAMAGE TO RENTED PREMISES (Ea occurrence) \$ 100,000 MED EXP (Any one person) \$ 5,000 PERSONAL & ADV INJURY \$ 1,000,000 GENERAL AGGREGATE \$ 2,000,000 PRODUCTS - COMPIOP AGG \$ 2,000,000
A	AUTOMOBILE LIABILITY <input type="checkbox"/> ANY AUTO OWNED AUTOS ONLY <input checked="" type="checkbox"/> HIRED AUTOS ONLY <input type="checkbox"/> SCHEDULED AUTOS NON-OWNED AUTOS ONLY		X	NN1919882	10/30/2025	10/30/2026	COMBINED SINGLE LIMIT (Ea accident) \$ 1,000,000 BODILY INJURY (Per person) \$ BODILY INJURY (Per accident) \$ PROPERTY DAMAGE (Per accident) \$
	<input type="checkbox"/> UMBRELLA LIAB <input type="checkbox"/> EXCESS LIAB <input type="checkbox"/> OCCUR <input type="checkbox"/> CLAIMS-MADE DED RETENTION \$						EACH OCCURRENCE \$ AGGREGATE \$
	WORKERS COMPENSATION AND EMPLOYERS' LIABILITY ANY PROPRIETOR/PARTNER/EXECUTIVE OFFICER/MEMBER EXCLUDED? (Mandatory in NH) If yes, describe under DESCRIPTION OF OPERATIONS below		N/A				PER STATUTE OTH-ER E.L. EACH ACCIDENT \$ E.L. DISEASE - EA EMPLOYEE \$ E.L. DISEASE - POLICY LIMIT \$
A	<input type="checkbox"/> Privacy Breach Coverage <input type="checkbox"/> Inland Marine Coverage		X	NN1919882	10/30/2025	10/30/2026	Limits \$25,000 Limits \$70,300

DESCRIPTION OF OPERATIONS / LOCATIONS / VEHICLES (ACORD 101, Additional Remarks Schedule, may be attached if more space is required)

Art Show Organizer Operations
 City of Keego Harbor, 2025 Beechmont St., Keego Harbor, MI 48320 is listed as Additional Insured in the Insured's General Liability Policy.

CERTIFICATE HOLDER**CANCELLATION**

Orchard Lake Fine Art Show® and West Bloomfield Township
 Event dates July 25 & 26, 2026
 Event location: Charter Township of West Bloomfield
 On Powers & Daily Roads

South of Maple, West of Orchard Lake Rod
 West Bloomfield MI 48322

SHOULD ANY OF THE ABOVE DESCRIBED POLICIES BE CANCELLED BEFORE THE EXPIRATION DATE THEREOF, NOTICE WILL BE DELIVERED IN ACCORDANCE WITH THE POLICY PROVISIONS.

AUTHORIZED REPRESENTATIVE

© 1988-2015 ACORD CORPORATION. All rights reserved.

Orchard Lake Fine Art Show
By Hot Works
Banner, size 4'x50' on Orchard Lake Road at Maddy Lane
Facing South
July 8, 2026 to July 27, 2026



VOTED TOP 100 ART SHOWS IN THE COUNTRY!

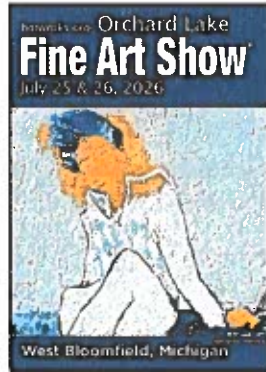

January 14, 2026

Ms. Tammy Neeb
City Clerk and City Manager
City of Keego Harbor
2025 Beechmont St.
Keego Harbor, MI 48320

Dear Ms. Neeb:

I hope all is well with you.

I am reaching out regarding the 23rd Orchard Lake Fine Art Show, taking place on July 25 & 26, 2026, in the heart of West Bloomfield.

Enclosed, please find the Sign Permit Application requesting approval to hang a 4'x50' netted banner across Orchard Lake Road at Maddy from Wednesday, July 8, to Monday, July 27, 2026. Also enclosed is a photograph of the banner, which has been displayed at this location for many years. This banner plays a vital role in spreading the word about this wonderful community event.

Additionally, I have included Hot Works' general liability insurance, listing the City of Keego Harbor as an additional insured.

As part of our commitment to arts education, we are proud to integrate the Youth Art Competition into the professional art show. This unique program encourages children in grades K-8 to create original artwork, which will be displayed throughout the event weekend. A total of \$250 in Youth Art Awards will be distributed. Applications are available at www.hotworks.org/kids, with a submission deadline of July 15.

At Hot Works, our goal is to ensure a positive experience for everyone involved in the show. Please feel free to reach out with any questions, comments, or suggestions at 248-762-2462 or Patty@HotWorks.org—I would love to hear from you.

Thank you for your time and assistance. I look forward to your response.

With Kind Regards,

Patty Narozny *Thank you!* 

Patty Narozny
Founder and Executive Producer, Orchard Lake Fine Art Show by Hot Works
Founder & Auxiliary Volunteer, Institute for the Arts & Education, Inc.

Enclosures

4/16/2026

MEETING GUIDELINES AND RULES

1. **Robert's Rules of Order:** Council members will follow the most recently published Robert's Rules of Order. In addition, a) rudeness shall not be tolerated; b) during an agenda item, speak to the agenda issue only; c) Board members may discuss agenda items before making a motion. For appeals and petitions, motions are made after the presentation of the case; d) speak into the microphone so that your comments can be heard and will be part of the public record.

2. **Cell Phones:** Cellular phones must be turned off or silenced during meetings.

3. **Consent Agenda:** The consent agenda is intended to expedite routine city business items. A Board member may remove an item from the Consent Agenda for the purpose of obtaining clarification, discussion, comment, or opposition.

4. **Public Comment:** Public comments will be provided for non-agenda related topics at the beginning of the meeting with a 3-minute limit per person. Audience members may speak once per issue. Large groups shall appoint two or three representatives to present their position to the Board during this time.

Please note, the public comment portion is not a question-and-answer session. Once the public has finished its comments, Board members shall be given the opportunity to comment regarding non-agenda related topics.

5. **Agenda Items:** Audience members may speak on agenda items with a 3-minute time limit per person. **Audience members may speak once per issue. Large groups may appoint two or three representatives to present their position to the Board during their agenda item, except during Special Assessment District (SAD) proceedings.**

6. **Time:** Chairperson or his/her designee shall use a timer to ensure adherence to time restrictions.

7. **Name and Residency:** Individuals speaking at any public meeting shall be requested to state their name and indicate whether they are a resident or non-resident.

8. **Interruptions:** No Board member or member of the public shall interrupt another individual when they are speaking.

9. **Presentations:** Lengthy presentations should be limited to a maximum of 30 minutes and scheduled through the City Clerk.

10. **Appeals:** Appeals from commissions and boards to the City Council shall be limited to a 15- minute presentation of the appeal.

11. **Public Hearing. The procedure for a public hearing will be:**

1. The department head will state the purpose for the public hearing and provide relevant information.
2. A petitioner, applicant, or appellant shall then be given the opportunity to address the Board, submit evidence, and state their case.
3. The Chair will open the public hearing and provide an opportunity for the public to address the item. Board members shall not speak during the public comment portion. Once the Chair closes the public comment portion, comments from the public shall no longer be accepted.

4/16/2026

4. After the public comment portion is closed, the Chair shall turn the item over to the Board. At this time, Board members will be given the opportunity to ask questions and make comments on the item.
5. A petitioner, applicant, or appellant shall be given the opportunity to respond prior to final action being taken.
6. After a final vote on a motion, no further comments will be taken from anyone.

12. **Closed Sessions:** It can be held at the beginning or end of the agenda.



To: City Council
Date: April 16, 2026
Subject: Keego Harbor Cookbooks

BACKGROUND

“What’s Cookin’ in Keego” cookbooks are requested to be re-printed to raise money for the betterment of the community at Fran Leaf Park.

RECOMMENDATION

Discussion

2/26/26

Dear Mayor and Council Members,

As some of you may remember, back in 2010 a cookbook committee had a cookbook printed, celebrating the Harbor Garden Club's 10th anniversary. The What's Cookin' in Keego? cookbook was printed using seed money from City Council and sold at City Hall.

Recently we've had a surge of interest, wanting to purchase copies of the old cookbook. Sharon Horger and I were part of the Cookbook Committee, which enabled us to get the information needed to have the books reprinted. We are requesting the same of Council as in the past, seed money to print the original cookbooks. We have obtained quotes for the reprints of 100, 200 & 300 books. Originally we ordered 400 books. It took awhile to sell all of them but we more than covered the printing costs and made enough of a profit to purchase roses bushes, soil and mulch for around the gazebo at Rose Sortor Park. We feel 200 books, at \$12 per would sell pretty easily, especially with the help of social media these days.

It is also important to us that the proceeds be used for the betterment of the community. Because of the loss of Roosevelt's playground, we'd like the proceeds to be used for future development of Fran Leaf Park.

Thank you for your consideration.

Sincerely,

Sharon Horger and Karen Meabrod

107572



of Books: 100
of Recipes: 405
Bill Code: 0325

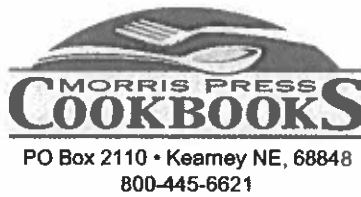

Tab 14

Generated: 3/30/2026
Generated By: teaton

Reprint Quote

Bill To: CITY OF KEEGO HARBOR
TREASURER-LINDA VOLL
PO BOX 665
KEEGO HARBOR, MI 48320-0665
248-682-1930

Book Type: Soft Cover

Cost of Books

Base Price (100 books, 405 recipes)	\$8.55
Reprint Discount	-\$0.25
Premium Format	\$0.30
Fillers	\$0.15
Color Personal Page Pics	\$0.10
Price Per Book	<u>\$8.85</u>

855.00 reprint
70.00 shipping

925.00 tot.

Miscellaneous Charges

Shipping/per Book	\$0.70
-------------------	--------

Please Note: This is NOT considered an order with our company. Corrections are free, but changes or additions could be subject to additional charges. This price estimate is valid for 30 days from the date on top of this form.

Overruns or underruns - As is customary in the printing trade, all orders are subject to 10% over or under the ordered quantity. Final billing will be adjusted accordingly.

All orders are subject to sales tax. An exempt form must be provided or the customer is liable for sales tax charges.

THIS IS NOT YOUR BILL! DO NOT PAY FROM THIS DOCUMENT!!

107572



of Books: 200
of Recipes: 405
Bill Code: 0325

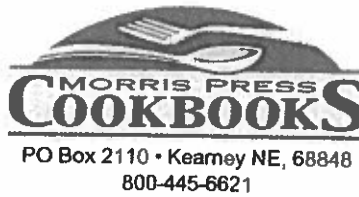

Generated: 3/30/2026
Generated By: teaton

Reprint Quote

Bill To: CITY OF KEEGO HARBOR
TREASURER-LINDA VOLL
PO BOX 665
KEEGO HARBOR, MI 48320-0665
248-682-1930

Book Type: Soft Cover

Cost of Books

Base Price (200 books, 405 recipes)	\$5.45
Reprint Discount	-\$0.25
Premium Format	\$0.30
Fillers	\$0.15
Color Personal Page Pics	\$0.10
Price Per Book	<u>\$5.75</u>

1,090.00 reprint
140.00 shipping

1230.00 tot.

Miscellaneous Charges

Shipping/per Book	\$0.70
-------------------	--------

Please Note: This is NOT considered an order with our company. Corrections are free, but changes or additions could be subject to additional charges. This price estimate is valid for 30 days from the date on top of this form.

Overruns or underruns - As is customary in the printing trade, all orders are subject to 10% over or under the ordered quantity. Final billing will be adjusted accordingly.

All orders are subject to sales tax. An exempt form must be provided or the customer is liable for sales tax charges.

THIS IS NOT YOUR BILL! DO NOT PAY FROM THIS DOCUMENT!!

107572



of Books: 300

of Recipes: 405

Bill Code: 0325

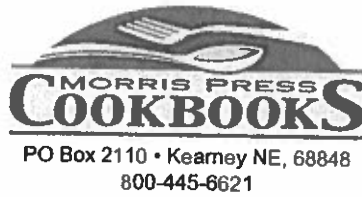

Generated: 3/30/2026

Generated By: teaton

Reprint Quote

Bill To: CITY OF KEEGO HARBOR
TREASURER-LINDA VOLL
PO BOX 665
KEEGO HARBOR, MI 48320-0665
248-682-1930

Book Type: Soft Cover

Cost of Books

Base Price (300 books, 405 recipes)	\$5.10
Reprint Discount	-\$0.25
Premium Format	\$0.30
Fillers	\$0.15
Color Personal Page Pics	\$0.10
Price Per Book	<u>\$5.40</u>

1,530.00 reprint
 210.00 shipping

 1,740.00 tot.

Miscellaneous Charges

Shipping/per Book	\$0.70
-------------------	--------

Please Note: This is NOT considered an order with our company. Corrections are free, but changes or additions could be subject to additional charges. This price estimate is valid for 30 days from the date on top of this form.

Overruns or underruns - As is customary in the printing trade, all orders are subject to 10% over or under the ordered quantity. Final billing will be adjusted accordingly.

All orders are subject to sales tax. An exempt form must be provided or the customer is liable for sales tax charges.

THIS IS NOT YOUR BILL! DO NOT PAY FROM THIS DOCUMENT!!



To: City Council
Date: April 16, 2026
Subject: Camper's Path

BACKGROUND

Mrs. Meabrod is requesting that City Council name the new Fran Leaf walkway, Camper's Path, in honor of the Roosevelt Summer Campers.

RECOMMENDATION

Discussion

3/6/26

Dear Keego Harbor Mayor and Council Members,

For many, many years, long before I started working there in '97, the Roosevelt Summer Campers swam at the Willow Beach Swim Site daily.

Every day, weather permitting, they would choose a swim buddy, line up along Roosevelt's wall, and then walk to the beach. They'd cross Cass Lake Rd, go between Margaret's Upholstering and what was a salon, proceed to Fran Leaf Park, continue down a sidewalk to Willow Beach St. and finally cross the Walking Bridge to the beach. This twice a day journey was part of the fun of going to the beach. In 2017 we noticed a "For Sale" sign in the empty lot next to the salon.

Fearing they'd lose part of their shortcut to the beach, the campers wrote letters to the TIFA board requesting that the city install a sidewalk on the property next to Margaret's Upholstering. That happened in late 2024! Thank you!

Recently, a former council member stated that the sidewalk along Fran Leaf Park leads to private property. People believed that information, and it was repeated at a Planning Commission meeting.

After questioning this with our City Manager Neeb, she confirmed with our assessors that the area in question is a platted alley, dedicated to public use.

Because of the thousands of trips Roosevelt Summer Campers made along this path and their effort to create a permanent extension of it, I am requesting that Council officially name the dedicated alley and new sidewalk "Camper's Path."

I believe it's important to acknowledge the camper's historic use of this path while also acknowledging its public intention set by our founders so many years ago.

Map A shows how long ago this alley has existed – 1917

Map B shows both paths, hopefully designated Camper's Path in honor of the Roosevelt Summer Campers.

Thank you for your consideration.

Sincerely, "Miss Karen" Meabrod



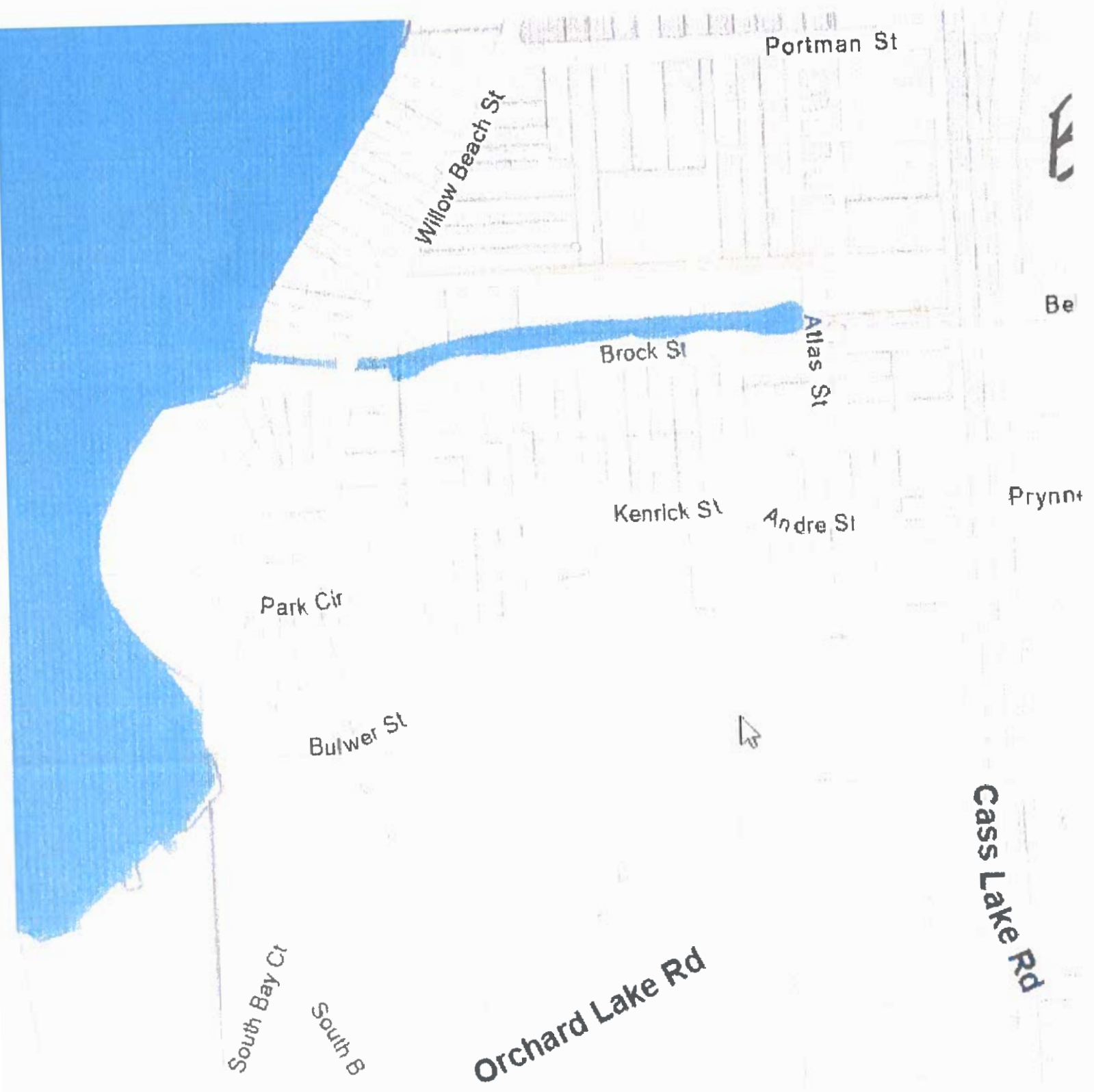



To: City Council

Date: April 16, 2026

Subject: Local Road Improvement Program 2026

BACKGROUND

1) The application period is now open for the 2026 Local Road Improvement Program (LRIP). The deadline for submission is May 28, 2026. The maximum funding match available from Oakland County is \$4,528, which requires an equal city match of \$4,528, resulting in a minimum total project cost of \$9,056. City Council approval is requested to allocate the required matching funds for participation in the program. Funds would be used toward eligible road improvements, such as crack sealing or other maintenance of city streets.

2) The City Council will allocate funds for the Crack Seal project on the FY26-27 budget. This project must be completed before the calendar year-end of 2026; the city has historically budgeted \$25,000 for crack sealing to ensure timely completion of this maintenance work.

RECOMMENDATION:

Discussion on local roads to crack seal.

1) Resolution to approve (or deny) Manager Neeb to enter the 2026 (LRIP) Local Road Improvement Program with Oakland County

2) Resolution to approve (or deny) Manager Neeb to move forward with a contractor for the 2026 LRIP project for FY 26-27 to not exceed \$\$ amount.

Attachment A

LOCAL ROAD IMPROVEMENT MATCHING FUND PROGRAM**STATEMENT OF PURPOSE**

Oakland County Government recognizes that Michigan law places the primary responsibility for road funding on the State and non-county local units of government. However, the County also recognizes that the law does permit a limited, discretionary role for the County in assisting a road commission and local units within a county by supporting some road maintenance and improvement efforts.

Accordingly, for many years Oakland County has voluntarily provided limited assistance to its cities, villages and townships (CVT's) and to the Road Commission of Oakland County (RCOC) by investing in a discretionary Tri-Party Road Program. Authorized under Michigan law, the County's tri-party funding contributions primarily facilitate safety improvement projects on CVT roads under the jurisdiction of the RCOC. By law, tri-party funds cannot be used to fund projects on roads solely under the jurisdiction of CVT's.

Recognizing a continuing need to better maintain local CVT streets and roads, yet being ever mindful of the County's limited responsibility for and jurisdiction over non-County roads and streets, Oakland County Government is continuing the success of the pilot program launched in 2016 that was more flexible than the current Tri-Party Road Program; one that allowed Oakland County to assist its cities and villages with maintenance and safety projects on non-County roads.

Not being the funding responsibility of County government, local CVT roads generally cannot be maintained or improved using County funds because doing so would be considered to be the "gifting" of County resources. However laudable the purpose, Michigan law generally forbids the gifting of government resources. To avoid application of the constitutionally-based gifting restriction, the state legislature must, and in this arena has, determined that a public benefit results from a taxpayer investment, one that provides a *quid pro quo* sufficient to avoid application of the gifting prohibition. Here, the legislature has determined that the economic development benefit presumed to accrue to a county as a result of local street and road investments can provide a sufficient *quid pro quo* to county taxpayers justifying a discretionary county investment in a non-county road, a benefit that constitutes a fair exchange for value and not a gift.

This legislative determination is set forth in 1985 P.A. 9, which amended 1913 P.A. 380, by adding a new section 2, which in pertinent part provides:

"(1) ...A county may grant or loan funds to a township, village or city located within that county for the purpose of encouraging and assisting businesses to locate and expand within the county...

(2) A loan or grant made under subsection (1) may be used for local public improvements or to encourage and assist businesses in locating or expanding in this state, to preserve jobs in this state, to encourage investment in the communities in this state, or for other public purposes."

Communities that wish to attract, retain and grow business, retain jobs and encourage community investment, needs a safely maintained road infrastructure. This road infrastructure must include both residential and commercial roads as workers and consumers need to get to and from work, shopping, schools and recreation. In a fiscally prudent and limited manner, the County wishes to

help its cities and villages accomplish this through its Local Road Improvement Matching Fund Program, commonly known as the Local Road Improvement Program (LRIP).

Any such program must be mindful of the limits imposed under Public Act 9. One important restriction Public Act 9 imposed on grants or loans made pursuant to Subsection 2 of the Act is the mandate that, "A grant or loan under this Subsection shall not be derived from ad valorem taxes except for ad valorem taxes approved by a vote of the people for economic development." This means that funding for an expanded local road assistance program cannot utilize proceeds from any of Oakland County's ad valorem tax levies since no levy has been approved by voters specifically for economic development.

Given this limitation, it appears that the state statutory revenue sharing appropriated to the County can provide a non-ad valorem source of funds that legally can be used to support the program. Competition for those funds, which are limited in amount, is fierce and their yearly availability is subject to the state legislative process. In the recent past, the State stripped all of those funds away from Michigan counties. Understanding that reality, it shall be the policy of the Oakland County Board of Commissioners that the Board shall not appropriate any County funds for a local road improvement matching fund program for non-County roads in any year where the State of Michigan fails to appropriate statutory revenue sharing funds to Oakland County in an amount sufficient to allow the County to first prudently address its core functions.

Act 9 imposes additional conditions on grants and loans. These include requirements that the loan or grant shall be administered within an established application process for proposals; that any grant or loan shall be made at a public hearing of the county board of commissioners and that the Board shall require a report to the county board of commissioners regarding the activities of the recipient and a report as to the degree to which the recipient has met the stated public purpose of the funding.

Understanding all of the above, the Oakland County Board of Commissioners hereby establishes the following Local Road Improvement Matching Fund Program:

PROGRAM SUMMARY

The Board of Commissioners established a Pilot Local Road Improvement Matching Fund Program through Miscellaneous Resolution #16103 for the purposes of improving economic development in Oakland County cities and villages. The County intends to continue this Program to assist its municipalities by offering limited matching funds for specific, targeted road maintenance and/or improvement projects on roadways under the jurisdiction of cities and villages.

A city or village participating in the Local Road Improvement Matching Fund Program shall match any fund authorized by the Board of Commissioners in an amount equal to a minimum of 50% of the cost of the total project award. County participation shall be limited to a maximum of 50% of the cost of the total project budget. Funding shall be utilized to supplement and enhance local road maintenance and improvement programs. Funding is not intended to replace existing budgeted local road programs or to replace funding already committed to road improvements.

PROJECT GUIDELINES

Program funding shall be utilized solely for the purposes of road improvements to roads under the jurisdiction of local cities and villages. Road improvements may include, but not be limited to, paving, resurfacing, lane additions or lengthening, bridges, or drainage as such improvements relate to road safety, structure or relieving congestion.

Program funding:

- **May** be utilized to supplement a local government's matched funding for the purposes of receiving additional federal transportation funding;
- **May not** be utilized to fulfill a local government's responsibility to fund improvements to state trunklines;
- **Shall be limited to** real capital improvements to roadways and shall not be utilized for other purposes, such as administrative expenses, personnel, consultants or other similar purposes;
- **Shall not be** utilized for non-motorized improvements, unless these improvements are included in a project plan for major improvements to a motorized roadway;
- **Shall be** utilized for projects that will result in a measurable improvement in the development of the local economy and contribute to business growth. Recipients shall be responsible for providing an outline of the economic benefits of the project prior to approval and for reporting to the Board of Commissioners after the completion of the project on the benefits achieved as a result of the projects.

ADMINISTRATION

Local Road Improvement Matching Fund Program projects may be appropriated by the Board of Commissioners in compliance with the County budget process. The amount of funds to be dedicated for the Program shall be determined by the Board of Commissioners on an annual basis. Program funding may be reduced or eliminated based upon the ability of the County government to meet primary constitutional and statutory duties. The Board of Commissioners expressly reserves the right to adjust the County matching funds share at any time based upon County budget needs.

In accordance with MCL 123.872, funds dedicated to the Local Road Improvement Matching Fund Program shall not be derived from ad valorem tax revenues. Program funding shall be limited to funds derived from the County's distribution from the Michigan General Revenue Sharing Act. Reduction or elimination of the County's distribution of revenue sharing funds may result in the elimination or suspension of the program.

Funding availability shall be distributed based upon a formula updated annually. The formula will consist of:

1. A percentage derived from the number of certified local major street miles in each city and village divided by aggregate total of certified local major street miles of all cities and villages in the County.
2. A percentage derived from the population of each city and village as determined by the last decennial census conducted by the U.S. Census Bureau divided by the aggregate total population of cities and villages in the County.

3. A percentage derived from the three-year rolling total of the number of crashes on city and village major local streets divided by the aggregate three-year rolling crash numbers for all city and village major local streets, using the most recent data available. The crash data will be supplied by the South East Michigan Council of Governments (SEMCOG).

Each city and village's percentage allocation shall be determined by adding each factor percentage and dividing that total by three. The amount of funds available for match shall be determined by the total amount of funds allocated by the Board of Commissioners added to an equal amount representing the match provided by local cities and villages.

The Chairman of the Board of Commissioners shall establish a Special Committee on the Local Road Improvement Program. This Special Committee shall consist of three members, with two members representing the majority caucus and one member representing the minority caucus. It shall be the responsibility of the Special Committee to direct the administration of this program, receive applications for program funding, and make recommendations of acceptance to the Board of Commissioners. The Special Committee may consult with County departments, staff, the South East Michigan Council of Governments (SEMCOG), and the Road Commission for Oakland County in the conduct of its business.

DISBURSEMENT

The Special Committee shall forward recommendations for approval of Local Road Improvement Matching Fund Program projects to the Chairman of the Board of Commissioners. This recommendation shall include a cost participation agreement between the County and participating municipality. Minimally, cost participation agreements shall include: responsibility for administering the project, the project location, purpose, scope, estimated costs including supporting detail, provisions ensuring compliance with project guidelines, as well as disbursement eligibility requirements. The cost participation agreement shall also require the maintenance of supporting documentation to ensure compliance with the following provisions:

1. Any and all supporting documentation for project expenditures reimbursed with appropriated funding shall be maintained a minimum of seven years from the date of final reimbursement for actual expenditures incurred.
2. The Oakland County Auditing Division reserves the right to audit any and all project expenditures reimbursed through the program.
3. The participating community understands and agrees that if it does not expend the entire Cost Participation Award under this Agreement on approved projects, then the remainder will be reimbursed to the County. The amount of any remainder shall be determined upon cancellation or completion of the approved project. Reimbursable funds shall be returned to the County within 90 days of such determination that the project has been cancelled, or the entire award has not been spent upon project completion.
4. In any case where the participating community is required to return money to the County under this Agreement, the participating community agrees that the County or the Oakland County Treasurer, at their sole option, shall be entitled to set off from any other funds of the participating community that are in the County's possession for any reason, including but not limited to, the Oakland County Delinquent Tax Revolving Fund ("DTRF"), if applicable. Any setoff or retention of funds by the County shall be deemed a voluntary assignment of that amount by the participating community to the County. The participating

community waives any claims against the County or its officials for any acts related specifically to the County offsetting or retaining such amounts. This paragraph shall not limit the participating community's legal right to dispute whether the underlying amount retained by the County was actually due and owing under this Agreement.

5. Nothing in this Section shall operate to limit the County's right to exercise any other legal rights or remedies under this Agreement or at law to secure reimbursement of funds which are due should they not be used by the participating community for the approved projects in the time frame set forth above. If the County pursues any legal action in any court against the participating community to secure repayment of unused funds, the participating community agrees to pay all costs and expenses incurred by the County, including court costs and attorney fees.

Upon receipt of recommendation of project approval from the Special Committee, the County Commissioner or Commissioners representing the area included in the proposed project may introduce a resolution authorizing approval of the project and the release of funds. Resolutions shall be forwarded to the Economic Development and Infrastructure Committee of the Board of Commissioners, who shall review and issue a recommendation to the Board on the adoption of the resolution. A public hearing shall be scheduled before the Board of Commissioners prior to consideration of final approval of the resolution.

The deadline for projects to be submitted for consideration shall be established by the Special Committee. The Special Committee may work with participating municipalities to develop a plan for projects that exceed that municipality's annual allocation amount. This may include a limited plan to rollover that municipality's allocation for a period of years until enough funding availability has accrued to complete the project, subject to funding availability.

Upon completion of project plans and execution of the cost participation agreement by the County and governing authority of the local municipality, the participating municipality shall submit an invoice in accordance with the terms and conditions included in the agreement. The Oakland County Department of Management and Budget Fiscal Services Division shall process payments in accordance with policies and procedures as set forth by the Department of Management and Budget and the Oakland County Treasurer.

In the event an eligible local unit of government chooses not to participate in the Local Road Improvement Matching Fund Program, or an approved project is cancelled, any previously undistributed allocated funding may be reallocated to all participating local units of government at the discretion of the Local Road Improvement Program Special Committee.

At the completion of each project, the participating local government shall provide a report to the Board of Commissioners regarding the activities of the recipient and the degree to which the recipient has met the stated public purpose of the funding as required by MCL 123.872.

**LRIP DISTRIBUTION FORMULA
2026**

City/Village	Cert Major Local		Crash Data 2022-					Max County	Minimum
	Road Miles	Miles %	Population	Pop %	2024	Crash %	Miles+Pop+Crash	Match	Project Cost
Auburn Hills	32.33	4.82%	24,360	3.02%	610	3.21%	3.68%	\$ 75,015	\$ 150,029
Berkley	15.63	2.33%	15,194	1.88%	237	1.25%	1.82%	\$ 37,069	\$ 74,137
Beverly Hills	10.99	1.64%	10,584	1.31%	156	0.82%	1.26%	\$ 25,600	\$ 51,200
Bingham Farms	1.02	0.15%	1,124	0.14%	2	0.01%	0.10%	\$ 2,049	\$ 4,098
Birmingham	21.87	3.26%	21,813	2.70%	954	5.02%	3.66%	\$ 74,574	\$ 149,149
Bloomfield Hills	8.83	1.32%	4,460	0.55%	132	0.69%	0.85%	\$ 17,408	\$ 34,816
Clarkston	1.48	0.22%	928	0.11%	26	0.14%	0.16%	\$ 3,208	\$ 6,416
Clawson	9.62	1.44%	11,389	1.41%	251	1.32%	1.39%	\$ 28,284	\$ 56,569
Farmington	7.36	1.10%	11,597	1.44%	121	0.64%	1.06%	\$ 21,525	\$ 43,049
Farmington Hills	58.36	8.71%	83,986	10.40%	1,697	8.93%	9.35%	\$ 190,335	\$ 380,670
Ferndale	20.99	3.13%	19,190	2.38%	513	2.70%	2.74%	\$ 55,719	\$ 111,437
Franklin	4.34	0.65%	3,139	0.39%	16	0.08%	0.37%	\$ 7,605	\$ 15,210
Hazel Park	17.12	2.55%	14,983	1.86%	524	2.76%	2.39%	\$ 48,657	\$ 97,313
Holly	7	1.04%	5,997	0.74%	89	0.47%	0.75%	\$ 15,310	\$ 30,620
Huntington Woods	6.95	1.04%	6,388	0.79%	34	0.18%	0.67%	\$ 13,622	\$ 27,245
Keego Harbor	1.93	0.29%	2,764	0.34%	7	0.04%	0.22%	\$ 4,528	\$ 9,055
Lake Angelus	0	0.00%	287	0.04%	0	0.00%	0.01%	\$ 241	\$ 482
Lake Orion	2.74	0.41%	2,876	0.36%	74	0.39%	0.38%	\$ 7,837	\$ 15,673
Lathrup Village	7.36	1.10%	4,088	0.51%	250	1.32%	0.97%	\$ 19,824	\$ 39,647
Leonard	2.34	0.35%	377	0.05%	9	0.05%	0.15%	\$ 3,008	\$ 6,017
Madison Heights	21.5	3.21%	28,468	3.52%	988	5.20%	3.98%	\$ 81,008	\$ 162,016
Milford	7.3	1.09%	6,520	0.81%	231	1.22%	1.04%	\$ 21,128	\$ 42,256
Northville	0.8	0.12%	6,119	0.76%	19	0.10%	0.33%	\$ 6,632	\$ 13,264
Novi	39.52	5.90%	66,243	8.20%	917	4.83%	6.31%	\$ 128,468	\$ 256,936
Oak Park	18.35	2.74%	29,560	3.66%	706	3.72%	3.37%	\$ 68,658	\$ 137,315
Orchard Lake Village	1.8	0.27%	2,238	0.28%	44	0.23%	0.26%	\$ 5,276	\$ 10,553
Ortonville	3.21	0.48%	1,376	0.17%	19	0.10%	0.25%	\$ 5,086	\$ 10,173
Oxford	6.01	0.90%	3,492	0.43%	110	0.58%	0.64%	\$ 12,952	\$ 25,905
Pleasant Ridge	3.59	0.54%	2,627	0.33%	50	0.26%	0.37%	\$ 7,630	\$ 15,261
Pontiac	70.21	10.47%	61,606	7.63%	2,413	12.70%	10.27%	\$ 209,114	\$ 418,228
Rochester	8.59	1.28%	13,035	1.61%	290	1.53%	1.47%	\$ 30,018	\$ 60,037
Rochester Hills	38.61	5.76%	76,300	9.45%	811	4.27%	6.49%	\$ 132,211	\$ 264,422
Royal Oak	63.96	9.54%	58,211	7.21%	2,615	13.77%	10.17%	\$ 207,150	\$ 414,300
South Lyon	4.43	0.66%	11,746	1.45%	42	0.22%	0.78%	\$ 15,859	\$ 31,719
Southfield	64.71	9.65%	76,618	9.49%	1,787	9.41%	9.52%	\$ 193,790	\$ 387,579
Sylvan Lake	2.58	0.38%	1,723	0.21%	7	0.04%	0.21%	\$ 4,311	\$ 8,622
Troy	57.34	8.55%	87,294	10.81%	1,762	9.28%	9.55%	\$ 194,405	\$ 388,810
Walled Lake	5.34	0.80%	7,250	0.90%	105	0.55%	0.75%	\$ 15,254	\$ 30,507
Wixom	10.49	1.56%	17,193	2.13%	352	1.85%	1.85%	\$ 37,653	\$ 75,306
Wolverine Lake	3.69	0.55%	4,544	0.56%	25	0.13%	0.41%	\$ 8,449	\$ 16,899
TOTAL	670.29	100.00%	807,687	100.00%	18,995	100.00%	100.00%	\$ 2,036,471	\$ 4,072,942



To: City Council

Date: April 16, 2026

Subject: Dollar Lake Kayak Launch

BACKGROUND

Due to receiving the enclosed letter from Mrs. Vasquez, City Council will discuss the location of the kayak launch on Dollar Lake.

RECOMMENDATION

Discussion

Jennifer Vasquez
3028 Andre Street
Keego Harbor, MI 48320

March 25th 2026

City of Keego Harbor
2025 Beechmont Street
Keego Harbor, MI 48320

RECEIVED

MAR 25 2026

CITY OF
KEEGO HARBOR

Dear Members of the City Council,

I am writing to express significant concerns about the proposed kayak launch access point near my home. I have considered this project for some time and did not come to this decision lightly. I originally fell into believe that this would not affect my family, but the fact that we have to put up signs and direct walkers with kayaks is a concern for public safety and trespassing. I also do not believe putting the kayaking launch directly in front of my home (at the tail end of the canal), adjacent to the parking lot offers a solution. This location topography is a gradient decline for water run off purposes; it's the drain area for the parking lot. The water at the end of the canal also recedes back in drier months and doesn't serve as a beneficial water access point. I also have concern on the legality of this kayak launch being allowed under current zoning.

First, I would like to address safety. The currently proposed kayak launch is estimated to be about 70 feet from the parking lot across a gradient topography that could lead to injury. I am worried that the public will walk in front of my home, without boundaries, and may end up in my yard or on my front porch. The risk of injury on or near my property is a concern.

Additionally, the alternative access point on Andre street is within a residential neighborhood, also on our dead-end street, raising major traffic and safety concerns. Putting in an additional parking lot in the vacant city lot is not ideal and would warrant approval for zoning changes. I also want to highlight that a kayak launch is similar to a public boat launch and may fall under a separate category of use, such as public recreation or water-dependent use, which requires a special-use permit and formal review, for this very reason.

That said, this could be an opportunity for the city to address Fran Leaf park as an alternative. This could focus on offering a solution to the canal's low spot near the walking

bridge, by improving that access route, they could give kayakers better, safer access to the lake, without disruption.

I urge you to reconsider this plan and ensure any public access point aligns with proper zoning and allotted legal and public review. I feel Fran Leaf location would appeal to the broader community.

Being that I intended to be neutral about this project in the beginning, I have received unsolicited input from neighboring residents who also feel Fran leaf fits the need for a kayak launch location better than this location. Thank you for your attention; I'm happy to discuss it further if needed.

Sincerely,
Jennifer Vasquez

BOUNDARY SURVEY

LEGEND

F.I.R. FOUND IRON ROD
 F.I.P. FOUND IRON PIPE
 S.I.R. SET IRON ROD

CASS LAKE (VAR. WD.)

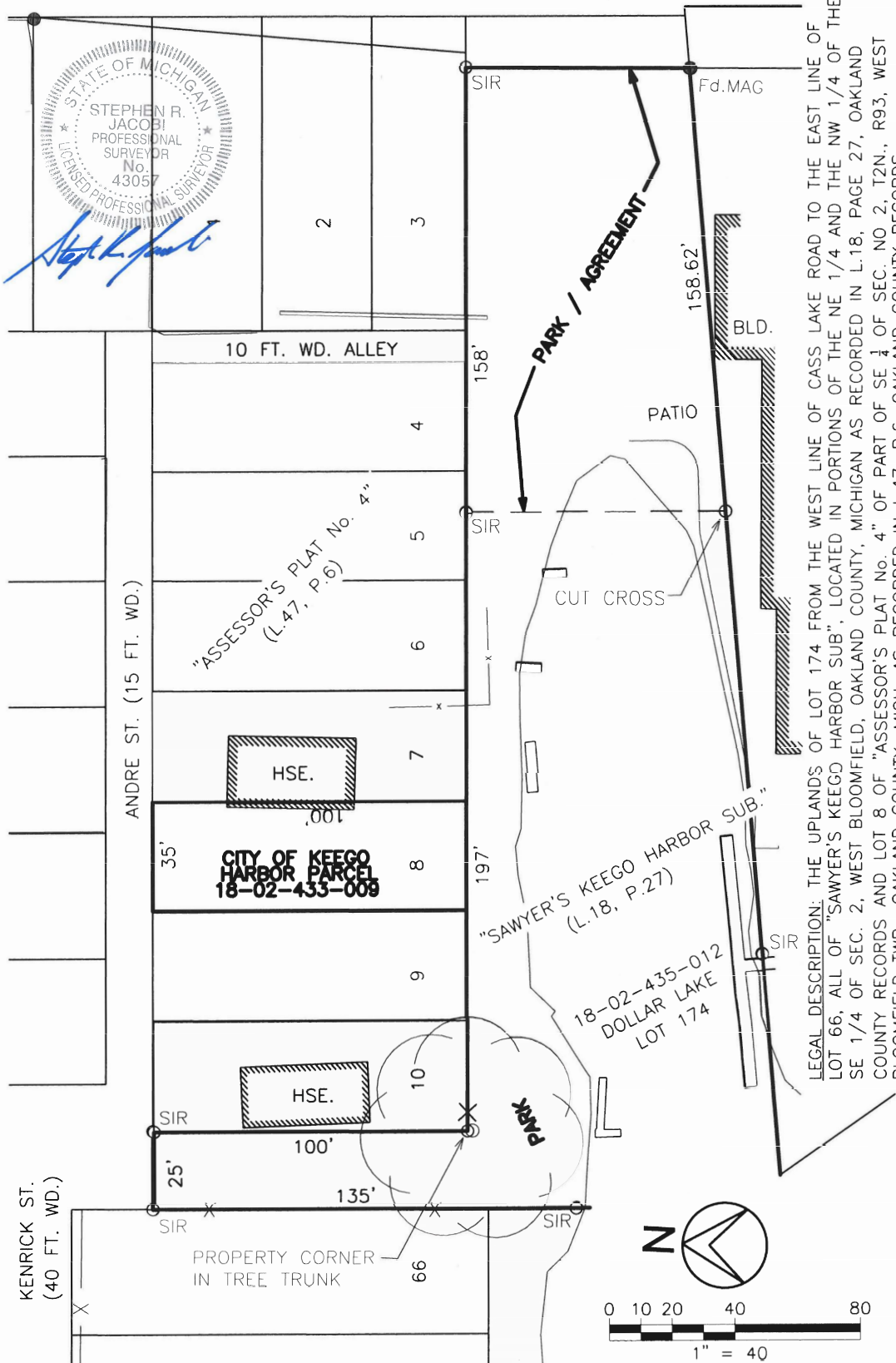
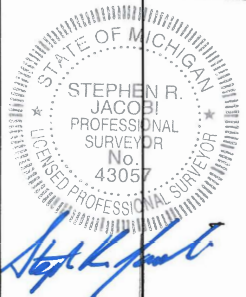

LEGAL DESCRIPTION: THE UPLANDS OF LOT 174 FROM THE WEST LINE OF CASS LAKE ROAD TO THE EAST LINE OF LOT 66, ALL OF "SAWYER'S KEEGO HARBOR SUB", LOCATED IN PORTIONS OF THE NE 1/4 AND THE NW 1/4 OF THE SE 1/4 OF SEC. 2, WEST BLOOMFIELD, OAKLAND COUNTY, MICHIGAN AS RECORDED IN L.18, PAGE 27, OAKLAND COUNTY RECORDS AND LOT 8 OF "ASSESSOR'S PLAT No. 4" OF PART OF SE 1/4 OF SEC. NO 2, T2N., R9S, WEST BLOOMFIELD TWP., OAKLAND COUNTY, MICH. AS RECORDED IN L.47, P.6, OAKLAND COUNTY RECORDS.

REV.	JOB NO. 20180516	 HUBBELL, ROTH & CLARK, INC CONSULTING ENGINEERS SINCE 1915	555 HULET DRIVE BLOOMFIELD HILLS, MICH.	P.O. BOX 824 48303 - 0824	SHEET NO.
	DATE 2/11/19		PHONE: (248) 454-6300 FAX (1st. Floor): (248) 454-6312 FAX (2nd. Floor): (248) 454-6359 WEB SITE: http:// www.hrcengr.com		1
					OF 1

CITY OF KEEGO HARBOR

**LICENSE AGREEMENT TO UTILIZE BOAT DOCKING ON
CITY OF KEEGO HARBOR PROPERTY ON DOLLAR LAKE**

THIS LICENSE AGREEMENT is made and entered into as of the ____ day of _____, 2024 (“Effective Date”) by and between the **CITY OF KEEGO HARBOR** (hereinafter referred to as the “City”) and _____ (hereinafter referred to as “Licensee”).

In consideration of the promises as set forth herein, the City grants _____ a License to use City of Keego Harbor Dollar Lake property as follows:

1. The City grants Licensee an exclusive, temporary license to use the City owned property at _____, Parcel No. _____, in the City of Keego Harbor (hereinafter referred to as the “Licensed Property”). (Attached Exhibit “A”)

2. The purpose of the license is to allow the Licensee to utilize City owned property to place a dock.

3. The term of this License Agreement shall be for a period beginning on the Effective Date stated above and ending on _____.

4. In consideration of the right to use the subject property during the term of this license, the Licensee agrees to:

A. Add the City of Keego Harbor as an added party insured to the Licensee’s homeowner liability insurance and provide a copy of such addition to the City of Keego Harbor within 14 days and provide proof of such addition within 14 days. Said additional party insured shall be give written notice if the homeowner’s insurance policy is cancelled or is not paid.

B. Utilize the licensed property in accordance will all of the ordinance requirements of the City of Keego Harbor and shall not commit any waste or damage to the Licensee.

5. Upon expiration, termination or cancellation of this License Agreement, by agreement or otherwise, the Licensee shall deliver the property to the City in the same condition as received by the Licensee.

6. The Licensee, its family members, employees, agents, and invitees shall protect, indemnify, and hold the City harmless from any and against all liabilities, damages, losses, claims, actions, costs, and expenses of any nature resulting from injuries or damage to persons or properties on or about the licensed property or in any manner connected with the use of the dock, condition or occupancy of the licensed property or any act or omission of the Licensee, its agents, contractors, or employees.

7. The Licensee agrees that the subject property of the Licensee's members and invitees in or about the property shall be at the sole risk and hazard of the Licensee, its members and invitees. The City shall not be liable or responsible for any loss, injury or damage to the Licensee, its members or invitees or any property of the Licensee, its members or invitees unless caused by acts or omissions of the City of Keego Harbor.

8. If the Licensee shall at any time be in default of performance of any of the conditions or obligations of this License Agreement and shall fail to remedy such default within seven (7) days after receipt of written notice of the default, the City may at its option, immediately and without further notice, terminate this license and immediately retake possession of the property without releasing the Licensee from any damages sustained by the City or from its obligation to restore the property. The remedies provided for herein in the event of default of the Licensee are in addition to and not in lieu of any other remedies or relief made available to the City under the laws of the State of Michigan. Waiver by the City of any default, breach or failure of this Licensee under this License shall not be construed as a waiver of any subsequent or different default, breach or failure.

9. All notices by either party to the other shall be made in person or by certified mail or, if such certified mail is returned undelivered, then by regular U.S. Mail. Notices to the City shall be made to the City Manager, 2025 Beechmont, Keego Harbor, Michigan, 48320, and notices to the Licensee shall be made c/o

10. If any terms or conditions of this License or the application to any person shall to any extent be invalid and unenforceable, the remainder of this License in the application of such term, covenant or condition to persons or events other than those to which it is held unenforceable shall not be affected and each term, covenant and

condition of this License shall be valid and be enforced to the fullest extent permitted by law.

IN WITNESS WHEREOF, authorized representatives of the parties to this Licensee Agreement, indicating their party's approval of the terms herein, have signed as of the dates set forth below.

Signed in the presence of:
Witnesses:

CITY OF KEEGO HARBOR

Print Name: _____

City Manager
Dated: _____

Print Name: _____

Print Name: _____

LICENSEE -

By: _____

Print Name: _____

Print Name: _____

Title: _____

Dated: _____



To: City Council
Date: April 16, 2026
Subject: City Signs

BACKGROUND

The city did not receive any responses from the RFP.

RECOMMENDATION

Update/Discussion

Harbor Graph X
 2545 Orchard Lake Rd
 Sylvan Lake, MI 48320-1535
 USA
 2486785432
 sales@graphXshop.com
 www.harborgraphx.com



Estimate

ADDRESS

Tammy
 City Of Keego Harbor

ESTIMATE # 1324

DATE 04/14/2026

ACTIVITY	QTY	RATE	AMOUNT
Indoor/Outdoor Signs:Aluminum Panel 44"x20" ALUMINUM BOARD SIGN PANEL BLUE CAST BACKGROUND GOLD CAST VINYL LETTERING CUT TO CUSTOM SHAPE POLES + INSTALLATION NOT INCLUDED	3	550.00	1,650.00

SUBTOTAL	1,650.00
TAX	0.00
TOTAL	\$1,650.00

Accepted By

Accepted Date



To: City Council

Date: April 16, 2026

Subject: Budget Workshop Date Discussion

BACKGROUND:

Budget workshop before the May (May 19th) Study Session at 5:30pm or 6pm.

RECOMMENDATION:

Discussion



To: City Council

Date: April 16, 2026

Subject: Volunteer Appreciation Dinner

BACKGROUND

- Location
- Date & Time

RECOMMENDATION

Discussion

*Keego Harbor City Council
Appreciates your contribution and your commitment
to our city. Please join us for an evening of
fun, dinner and dessert.*

*2019 Appreciation Dinner
Monday February 25, 2019
6:00 p.m. cash bar 7:00 p.m. dinner*

*Gino's Pizzeria and Restaurant
1999 Cass Lake Road*

*R.S.V.P.: deputyclerk@keegoharbor.org
by Friday February 15, 2019*

*Your one guest is \$15.00 which can be paid at
City Hall by
Friday February 15, 2019*



To: City Council
Date: April 16, 2026
Subject: City Manager Office Furniture

BACKGROUND

The current desk in the City Manager's office is **not ergonomically suitable**. To replace it, three bids were received as follows:

Vendor	Bid Amount	Notes
Castell	\$2,535.00	Includes \$50.00 credit for removal of existing desk
Rightsize	\$3,443.00	Standard bid
ISCG	\$2,983.64	Standard bid

After reviewing the bids, **Castell** offers the **most cost-effective option** at \$2,535.00, while also providing a credit for removal of the current desk. The desk offered by Castell meets ergonomic standards and functional requirements for the City Manager's office.

RECOMMENDATION

Resolution to Approve (or deny) the purchase of the City Manager office desk from **Castell** in the amount of **\$2,535.00**.



Workspaces in Balance
April, 7, 2026

Keego Harbor City Manager Office

Look Book

Tab 21



CONTENTS

- Castell Profile
- Floor Plan
- Proposed Product
- Budgetary Pricing

COMPANY PROFILE

Castell is a workplace design consultancy and office furniture dealer serving metro Detroit and the greater Midwest for 25 years. Formerly known as Office Furniture Solutions, Castell provides custom tailored, high quality, high design workspace furnishings, architectural products and complementary services that help companies balance the economic and performance demands of today's workforce.



INTERIOR DESIGN & SPACE PLANNING

Our staff of degreed design professionals provide a wide range of design services including:

- ❑ PROGRAMMING CUSTOMER REQUIREMENTS
- ❑ CREATIVE DESIGN & SPACE PLANNING
- ❑ FULL PRODUCT SPECIFICATION & DOCUMENTATION
- ❑ FURNITURE & ARCHITECTURAL FINISH SELECTION

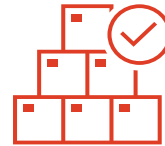

DELIVERY & INSTALLATION

At Castell, our installers are direct employees and manufacturer certified. All Castell installers will arrive at your facility in uniform, driving Castell vehicles. In addition, we have service technicians available 24 hours a day, in case an emergency arises. A dedicated installation manager and job site supervisor will be on your job from start to finish.

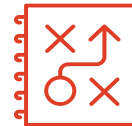

PROJECT MANAGEMENT

Our approach to project management provides customers with a single point of contact throughout the project. The project manager attends pre-construction meetings in the planning stage, is on-site throughout the installation and conducts the final walk through with you when complete.

FLOOR PLAN

Floor Plan

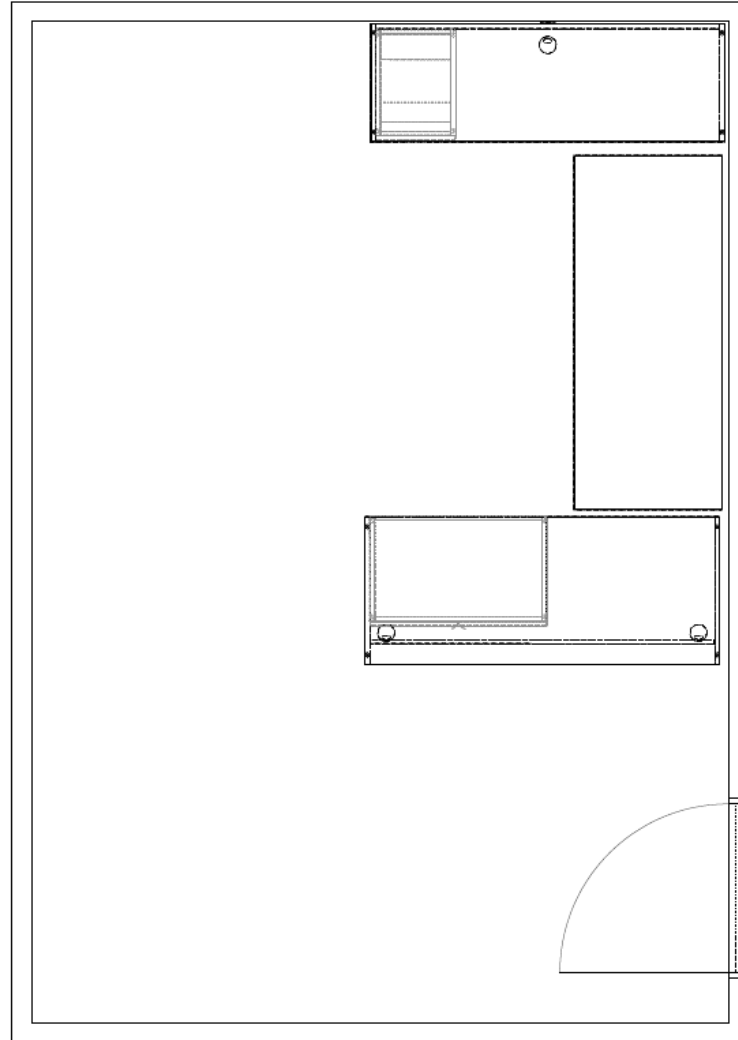

PROPOSED PRODUCTS

Office

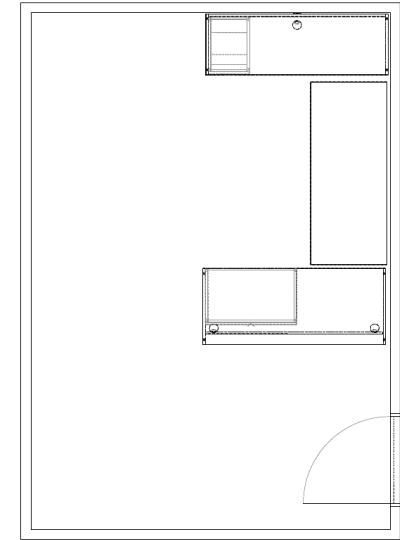
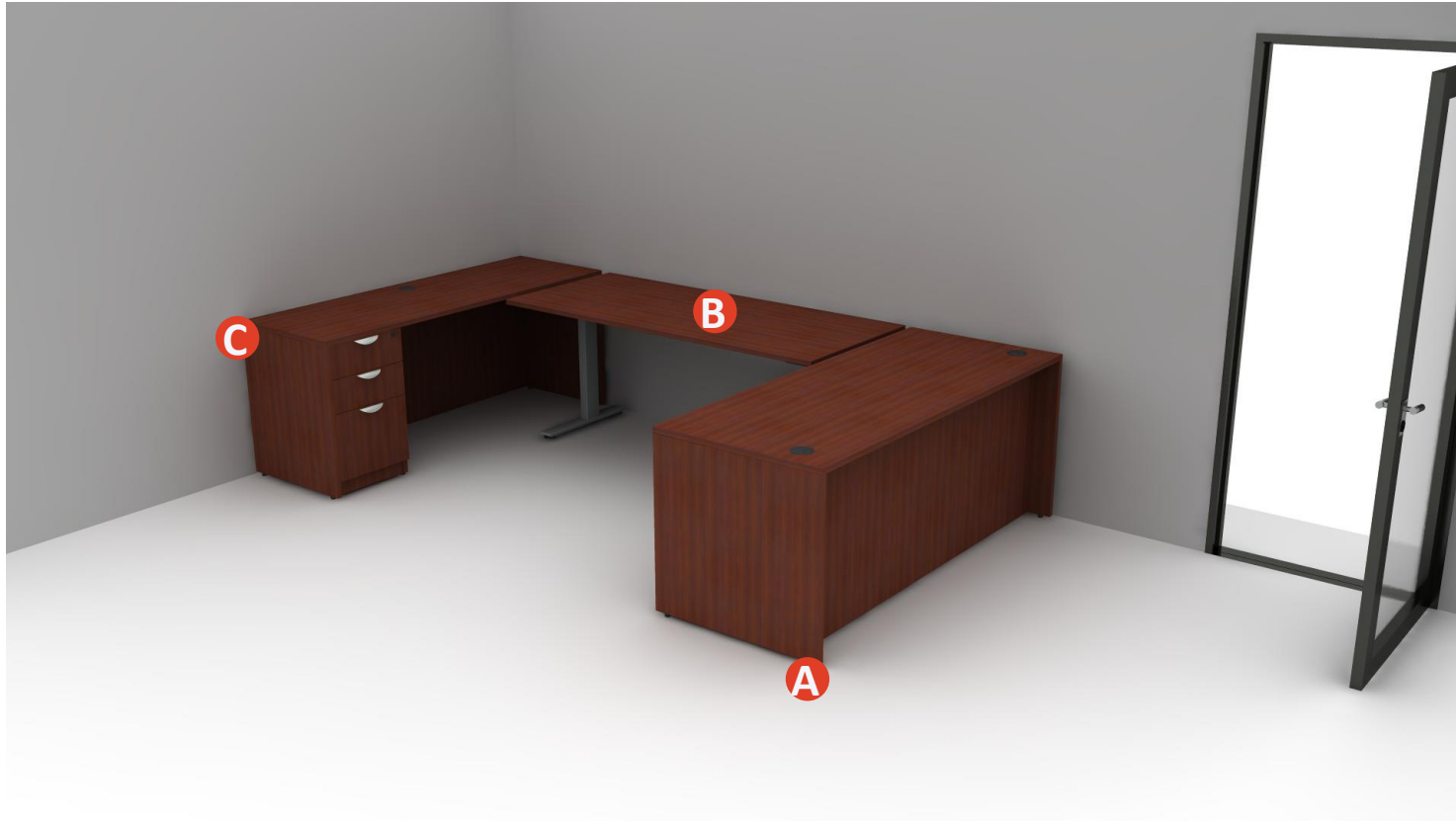

FLOOR PLAN KEY

PRODUCT INFORMATION:

- (A) - Desk Shell 30" x 71" with Mixed Storage
- (B) - 30" x 71" Height Adjustable Desk
- (C) - 24" x 71" Credenza with Box/Box/File Storage

BUDGETARY PRICING

Budgetary Pricing

AREA/ITEM	QUANTITY	UNIT PRICE	EXT. PRICE	MI SALES TAX	TOTAL
Furniture					
U Shape Height Adjustable Desk	1	\$ 1,635.00	\$ 1,635.00		\$ 1,635.00
Pre Owned Monitor Arm	2	\$ 100.00	\$ 200.00		\$ 200.00
		SUBTOTAL	\$ 1,835.00	\$ -	\$ 1,835.00
Installation					
			\$ -	\$ -	\$ -
Furniture Installation	1	\$ 750.00	\$ 750.00	\$ -	\$ 750.00
		SUBTOTAL	\$ 750.00	\$ -	\$ 750.00
PROJECT SUBTOTAL			\$ 2,585.00	\$ -	\$ 2,585.00
Credit for Existing Desk			\$ 50.00	\$ -	\$ 50.00
PROJECT TOTAL			\$ 2,535.00	\$ -	\$ 2,535.00

THANK YOU



2175 E. West Maple Road
Commerce Township, MI 48390
www.castellspaces.com

Furniture Proposal

TAB 21

2025 Beechmont St.
Keego Harbor, MI 48320
Submitted April 9, 2026



Your Dedicated Team



Kyle Kruschwitz

Workplace Solutions Manager

Kyle has worked in the commercial furniture industry for 25+ years and holds a B.F.A. in Interior Design. He began his career in facilities management and then worked at various furniture dealers before starting his own business.



Nick Weise

Business Development

Nick launched Rightsize's Michigan office in 2015 after several successful years in commercial interiors at the installation, manufacturer and dealer level. With 15+ years of industry experience, he brings a wealth of knowledge to his mission of growing Rightsize both locally and nationwide.



Courtney Eames-Hoyt

Space Planner/Specifier

Courtney has over 15 years of experience designing functional, human-centered spaces across residential, commercial, and healthcare environments. Courtney brings both expertise and heart to every project. Grounded in a deep passion for inclusivity and diversity, she designs spaces (and teams) where everyone belongs.



Rick Camerano

Project Coordinator

With 20 years of experience, Rick is a seasoned professional in managing complex projects, allowing him to excel in effective planning, resource allocation, and risk management.



Sarah Ward

Project Administrator

Sarah brings with her a resourceful, quick-learning mindset and is ready to provide excellent administration and design support to the team. Sarah has a BFA in Interior Design from the University of Kentucky, and most recently worked as an Interior Designer in Lexington, Kentucky for an interior design firm that specialized in commercial interiors.



Craig Miller

Field Supervisor | Project Manager

Craig has 30+ years of experience in field supervision and on-site project management.



About Us



Nationwide Furniture Dealer

Multi-market specialists, we are where you



Turnkey Partner

Single source from concept to completion



Sustainably Sourced

Proudly representing eco-friendly workspace solutions



Accelerated Delivery Model

We get it done fast, on time and on budget



Eco-Friendly Decommissioning

Less than 5% of FF&E assets end up at a landfill



Day 2, Year 2 Forever Service

We extend our services far beyond project completion



The Choice of Iconic Brands

100,000+ Customers Served Nationwide

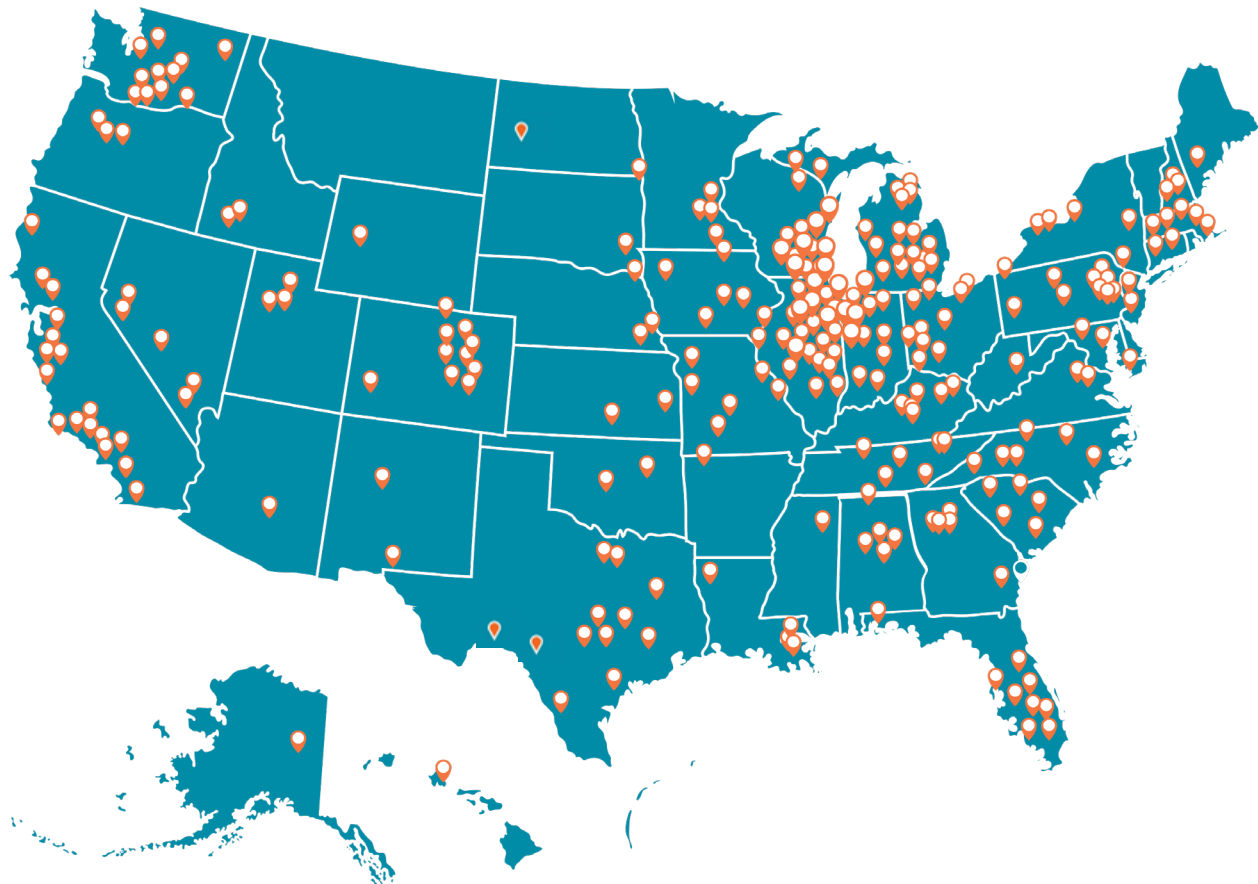



Our Capabilities

Plan

- Needs analysis including workplace efficiency and growth considerations
- Schematics, space planning and 3D renderings
- Coordinate and oversee transition details to minimize business disruptions

Furnish

- An independent furniture dealer that represents many premium manufacturers
- In addition to new furniture, we have access to the Midwest's largest inventory of premium preowned and remanufactured office furniture for a wide range of aesthetic and budgetary options, offering truly customized solutions to meet each client's unique needs
- Nationwide delivery and installation provided by union and non-union labor

Service

- Decommissioning
- Relocation
- Reconfiguration
- Commercial Storage
- Furniture Rental



Project Delivery Process

From workflow analysis and space planning, to furniture procurement and installation, we oversee every detail of office transitions.



Our Work



730 N Franklin

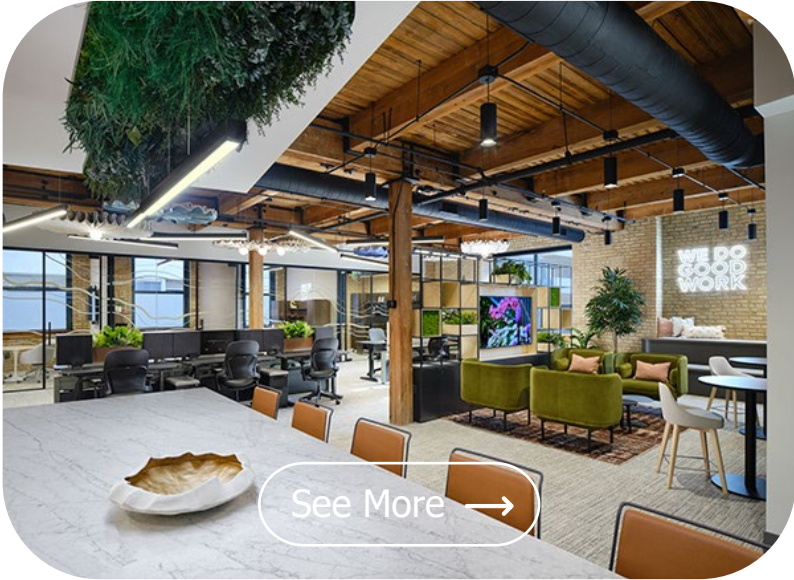

BOLLINGER MOTORS

191 N Wacker

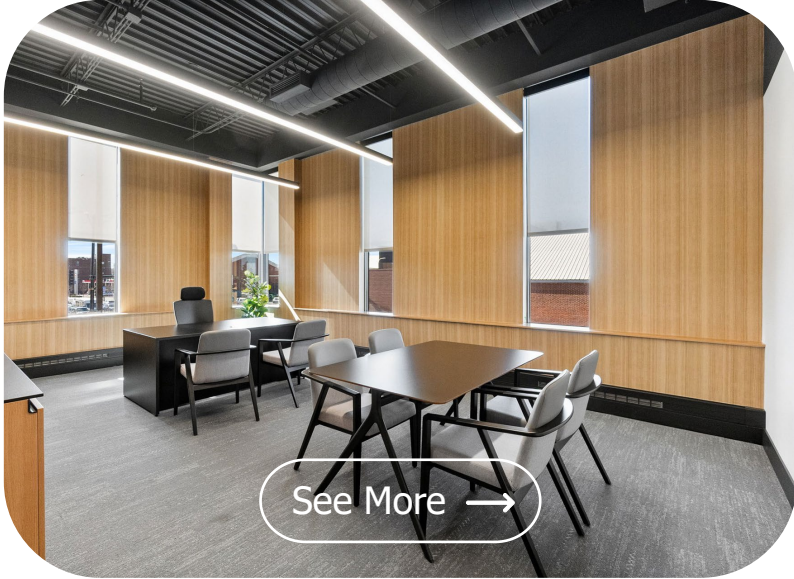
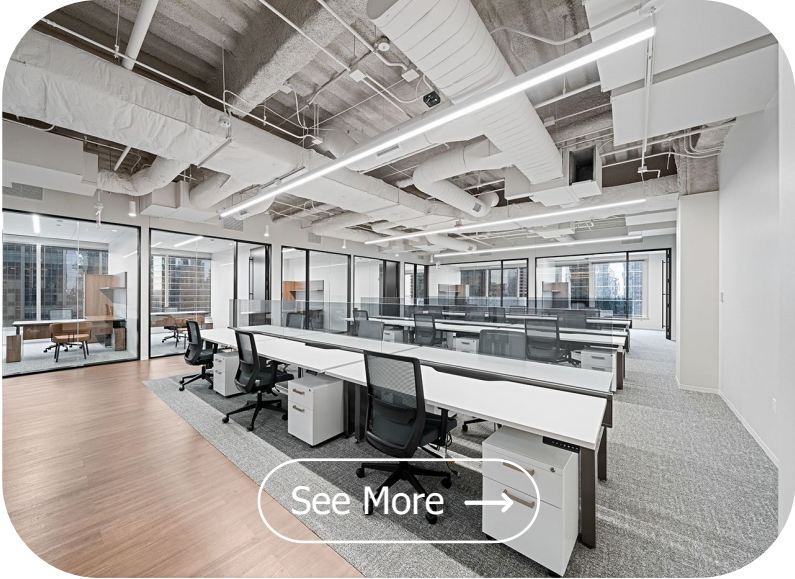
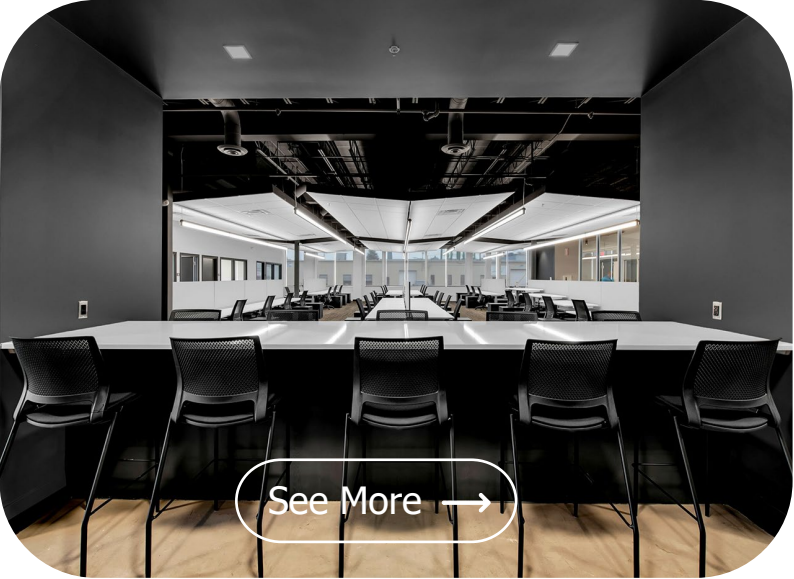

Day 2, Year 2 Forever Service

Our approach to Day 2 services extend far beyond a day, a week, or a year. Our follow up services are ongoing and forever. Client needs vary post initial installation, and we have developed a predictable, repeatable, consistent methodology for handling a variety of needs.



Repeat Client Relationships



Ergonomic Adjustments



Warranty Items



Furniture Refresh





Project Scope



PO-01-OPT 2

QTY: 1 | RF SERIES | HEIGHT ADJUSTABLE DESK

PRICE: \$1,885.00

- 72"W x 30"D desk shell
 - b/b/f pedestal
- 60"W x 30"D height adjustable table
 - Mini pencil drawer
- 72"W x 24"D credenza shell with f/f pedestal
- Note: Dual monitor arm and wire management priced separately

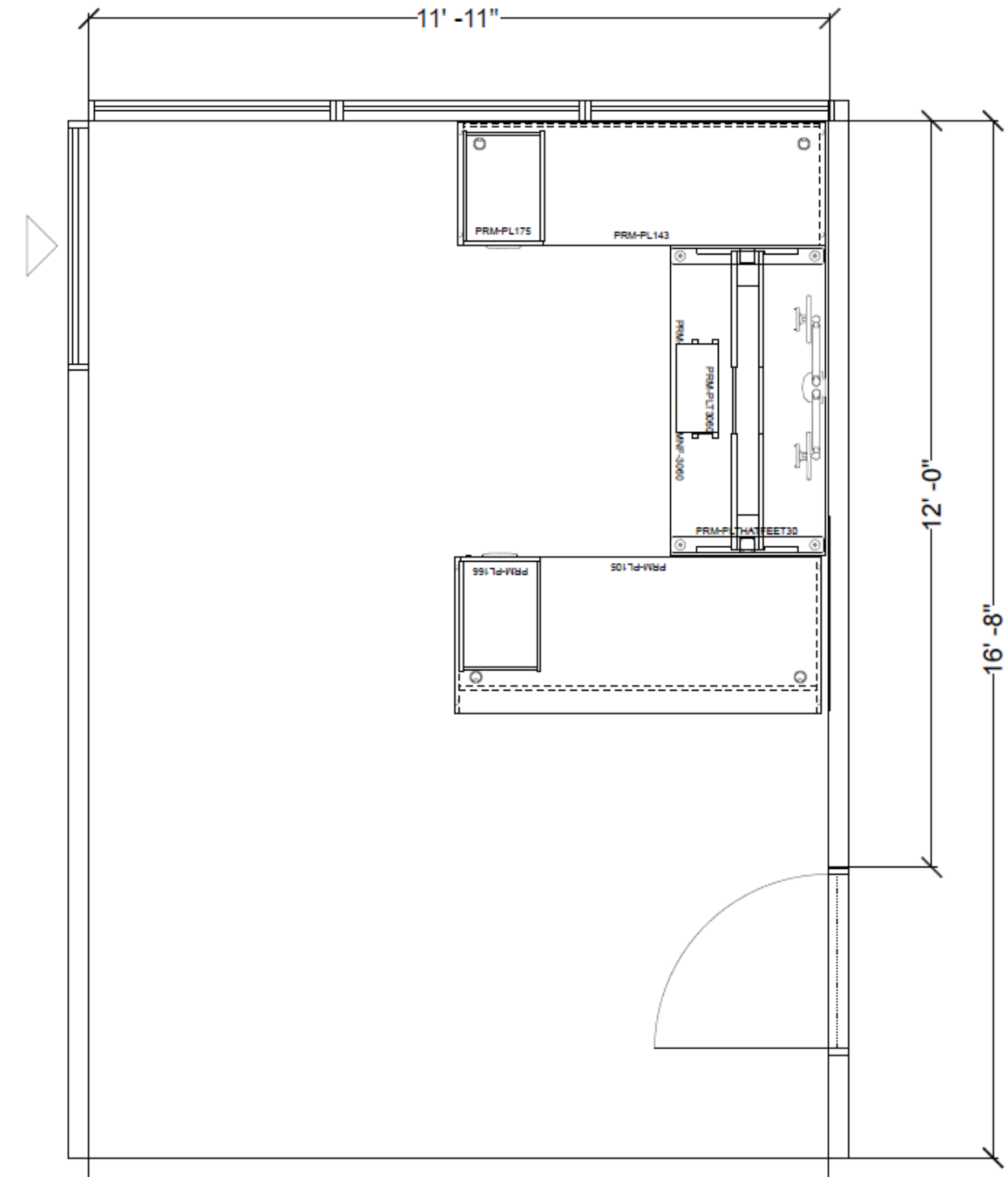

AC-01

QTY: 1 | HAT COLLECTIVE | E2 DUAL MONITOR ARM

PRICE: \$289.00

- Clean lines and a modern silhouette provide a stylish profile for either home or office.
- Allows monitors to be placed at an ergonomically correct distance from the user's eyes to increase comfort and productivity no matter where a person is working.
- Portrait-to-landscape rotation feature reduces stress on the neck and shoulders.
- Tension indicator allows the user to pre-counterbalance arms based on monitor weight prior to installation.
- VESA-monitor compatible – 75mm & 100mm VESA adapters included.

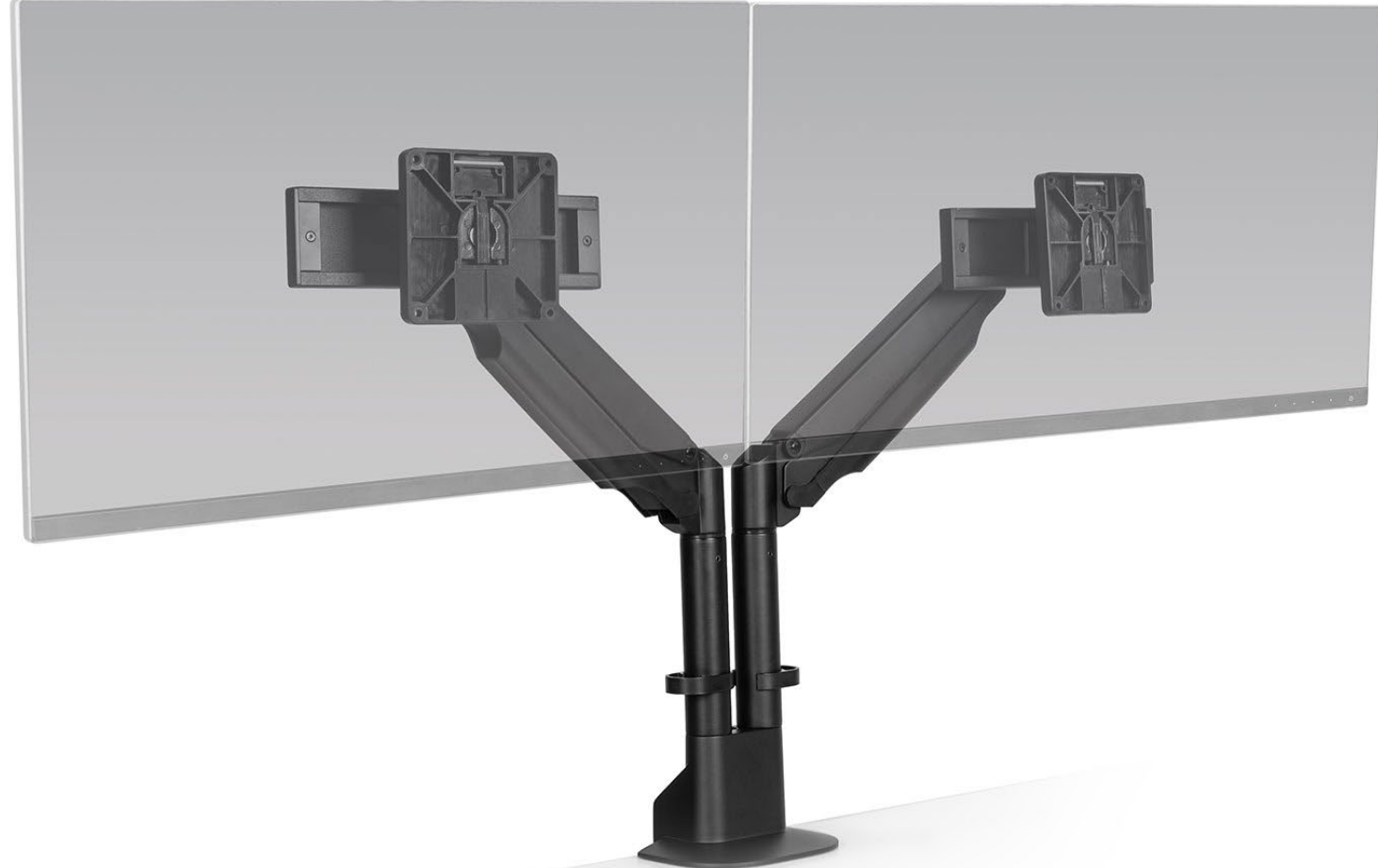

AC-02

QTY: 1 | HAT COLLECTIVE | POCKET CABLE MGMT

PRICE: \$99.00

- Includes 12 Velcro straps that securely lock in your wires.
- Flame resistant fabric protects against cord damage.
- Dual straps on the inside provide quick access to add or remove cords and devices instantly.
- The Pocket can be set up in minutes, allowing the user to achieve true cable organization.



Project Overview

Scope of Work

- Furniture for (1) Private Office desk set as shown, (1) dual monitor arm (1) wire management basket
- Removal of (1) existing desk, (1) credenza and (1) table
- AutoCAD furniture layouts and drawing revisions. Detailed furniture installation drawings (at time of install).
- Assistance with fit & finish selections.
- Procurement of all furniture per scope.
- Non-Union Labor performed with after hours delivery and regular hours installation.
- Coordination with other trades, and on-site project management throughout the duration of the project.
- Rightsize will receive, quality control and store product, up to 30 days, at no additional cost until the jobsite is ready for installation.
- Rightsize disclaims any liability for the current condition of the client’s existing furniture, both prior to and following its relocation or reconfiguration.

Proposed Product Lines	Est. Lead Times
OFC PREOWNED	2 – 4 WEEKS
HAT	2 – 4 WEEKS

Quick Summary

Furniture: \$2,273.00
Freight & Surcharges: \$290.00
Delivery, Installation & Removal: \$875.00
Sales Tax (EXEMPT): \$0.00
Total: \$3,443.00

CLIENT INITIALS & DATE



Thank You



48" TACKBOARD NEXT TO MAP



U-DESK LAYOUT OPT (A) RENDER

NTS

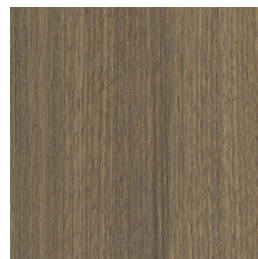

"Neo Walnut" (LAM)

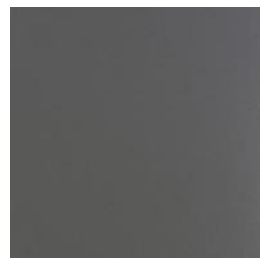

"Graphite" (TRIM)

NOTES:

FINISHES SHOWN REQUIRE FINAL APPROVAL

DESK ACCESSORIES SHOWN ARE NOT INCLUDED IN ISCG QUOTE

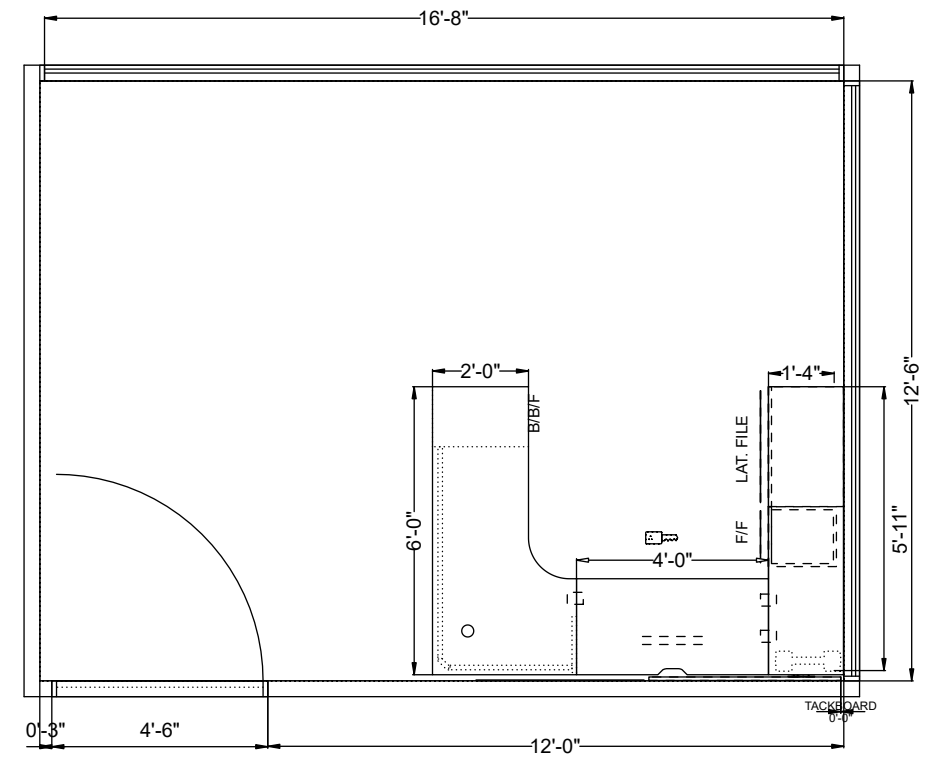

FURNITURE LAYOUT (A)

1/4" = 1'

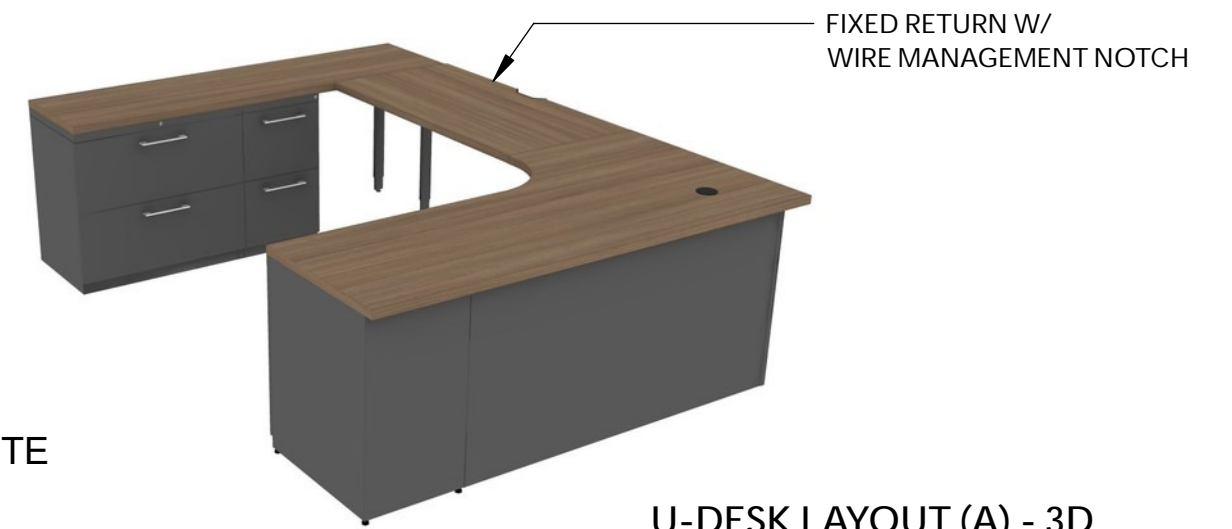

U-DESK LAYOUT (A) - 3D



612 N. Main St. Royal Oak, MI 48067

#25100 | City of Keego Harbor

FINAL LAYOUT FOR APPROVAL - 5.16.25

2025 Beechmont St, Keego Harbor, MI

Date: 5/16/2025
 Scale: SEE VIEWS
 Sales: MJW
 Designer: KW
 File Name: x:\DRAWINGS\2025\25100\2
 Revisions:
 Page Number: 1/1



ISCG
 612 N. Main St.
 Royal Oak, MI 48067
 Phone: (248)399-1600
 Fax: (248)399-1601
 www.iscginc.com

Tab 21

QUOTE
2493.001
Project 2493

Date Printed: Mar 27, 2026

Sold To: 16195-00
 CITY KEEGO HARBOR
 2025 BEECHMONT ST
 KEEGO HARBOR, MI 48320 US

Bill To: 16195-00
 CITY KEEGO HARBOR
 2025 BEECHMONT ST
 KEEGO HARBOR, MI 48320 US

Install Location: 16195-00
 CITY KEEGO HARBOR
 2025 BEECHMONT ST
 KEEGO HARBOR, MI 48320 US

Attn:

Attn: Accounts Payable

Attn:

Customer PO	Reference	Sales Person	Terms
	U DESK	MARY JO WARNER	50% DEPOSIT, BALANCE NET 30

Line	Item	Description	Qty	Unit Price	Extended	
1	WUAC-WSG	CASEGOODS, GROMMET, SVC Tag 1:OPT A U-DESK	1.00	5.29	5.29	T
2	WUAW-1500-PNH	WORKSURFACE, HORIZ WIRE MANAGER Tag 1:OPT A U-DESK	1.00	103.90	103.90	T
3	WURA-2448-LJSA	WORKSURFACE, RECT,24DX48W, LAM,EDGEBAND,STD CORE, NOTCHED Tag 1:OPT A U-DESK Options: ,H-KL-NEO WALNUT, GRADE B ,HP-KL-NEO WALNUT, GRADE A	1.00	96.13	96.13	T
4	ZUBF-0000-PN	FLUSH MOUNT PLATE Tag 1:OPT A U-DESK	3.00	5.40	16.20	T
5	ZZFK-1800-PNFG	COMPOSE WORKSURFACE DBL SUPPORT LEG,ALUMINUM,18IN.D Tag 1:OPT A U-DESK Options: ,TR-J-GRAPHITE, GRADE A	1.00	111.40	111.40	T
6	LSET-3	HW,LOCK SET, KEYED ALIKE, LOCK PLUG AND KEY, QTY OF 3 Tag 1:OPT A U-DESK Options:	1.00	0.00	0.00	



ISCG
 612 N. Main St.
 Royal Oak, MI 48067
 Phone: (248)399-1600
 Fax: (248)399-1601
 www.iscginc.com

QUOTE
2493.001
Project 2493
 Date Printed: Mar 27, 2026

Sold To: 16195-00
 CITY KEEGO HARBOR
 2025 BEECHMONT ST
 KEEGO HARBOR, MI 48320 US

Bill To: 16195-00
 CITY KEEGO HARBOR
 2025 BEECHMONT ST
 KEEGO HARBOR, MI 48320 US

Install Location: 16195-00
 CITY KEEGO HARBOR
 2025 BEECHMONT ST
 KEEGO HARBOR, MI 48320 US

Attn:

Attn: Accounts Payable

Customer PO	Reference	Sales Person	Terms
	U DESK	MARY JO WARNER	50% DEPOSIT, BALANCE NET 30

Line	Item	Description	Qty	Unit Price	Extended	
		.LX-BP-CHROME, GRADE A				
7	TA01-0225	TABLE, WIRE MNGR RETAINING CLIPS, PLANES (PKG OF 10) Tag 1:OPT A U-DESK	1.00	10.64	10.64	T
8	KUAF-XXXX	TACKBOARD,WALL-MOUNTED, UNIVERSAL,VARIABLE SIZE, EXACT, TAILORED - FRENCH CHALK, GRADE A, 26"X40" Tag 1:OPT A U-DESK Options: .PY-0FC-FRENCH CHALK, GRADE A .36IN .48IN	1.00	125.70	125.70	T
9	JDAL-3672-JARSFN44	X SERIES, CORNER WRAP EXT, LAM,36X72,SUPPORT STL,PED,RH, FUL MOD,NO CABLE MGT,24 D Tag 1:OPT A U-DESK Options: .H-KL-NEO WALNUT, GRADE B .HP-KL-NEO WALNUT, GRADE A .TR-J-GRAPHITE, GRADE A .TR-J-GRAPHITE, GRADE A	1.00	537.00	537.00	T
10	JLPD-0230-S8A	X SERIES,27.5"H X 30"W,LATERAL FILE,FILE,PTD DRAWER FRONT, PROUD,PTD LOCK BAR, ATTACHED,LINEAR PULL,GLIDES Tag 1:OPT A U-DESK Options:	1.00	315.43	315.43	T



ISCG
 612 N. Main St.
 Royal Oak, MI 48067
 Phone: (248)399-1600
 Fax: (248)399-1601
 www.iscginc.com

QUOTE
2493.001
Project 2493
 Date Printed: Mar 27, 2026

Sold To: 16195-00
 CITY KEEGO HARBOR
 2025 BEECHMONT ST
 KEEGO HARBOR, MI 48320 US

Bill To: 16195-00
 CITY KEEGO HARBOR
 2025 BEECHMONT ST
 KEEGO HARBOR, MI 48320 US

Install Location: 16195-00
 CITY KEEGO HARBOR
 2025 BEECHMONT ST
 KEEGO HARBOR, MI 48320 US

Attn:

Attn: Accounts Payable

Customer PO	Reference	Sales Person	Terms
	U DESK	MARY JO WARNER	50% DEPOSIT, BALANCE NET 30

Line	Item	Description	Qty	Unit Price	Extended	
11	JTPL-1872-JYJYS	,TR-J-GRAPHITE, GRADE A ,LR-BP-CHROME, GRADE A X SERIES, COMMON TOP, PRD FRNT, LAM TOP, 18.75DX72W, 3MM PLSTC USR, 1MM LH,3MM BCK,1MM RH Tag 1:OPT A U-DESK Options: ,H-KL-NEO WALNUT, GRADE B ,HP-KL-NEO WALNUT, GRADE A	1.00	218.44	218.44	T
12	JPAJ-18-S8	X SERIES,PEDESTAL,ATTACHED, F/F,18"D,PTDDRWFRT, STL LKRL, LINEAR PULL Tag 1:OPT A U-DESK Options: ,TR-J-GRAPHITE, GRADE A ,LR-BP-CHROME, GRADE A	1.00	206.27	206.27	T
13	JPDH-24-S8RF	X SERIES,PEDESTAL,ATTACHED DESK,BOX/BOX/FILE,24"D,PTD DRAWER FRONT,PTD LOCKBAR, LINEAR PULL,RH,FULL MOD Tag 1:OPT A U-DESK Options: ,TR-J-GRAPHITE, GRADE A ,LR-BP-CHROME, GRADE A	1.00	239.86	239.86	T
14	SURCHARGE	HAWORTH SURCHARGE	1.00	187.26	187.26	T



ISCG
 612 N. Main St.
 Royal Oak, MI 48067
 Phone: (248)399-1600
 Fax: (248)399-1601
 www.iscginc.com

QUOTE
2493.001
Project 2493
 Date Printed: Mar 27, 2026

Sold To: 16195-00
 CITY KEEGO HARBOR
 2025 BEECHMONT ST
 KEEGO HARBOR, MI 48320 US

Bill To: 16195-00
 CITY KEEGO HARBOR
 2025 BEECHMONT ST
 KEEGO HARBOR, MI 48320 US

Install Location: 16195-00
 CITY KEEGO HARBOR
 2025 BEECHMONT ST
 KEEGO HARBOR, MI 48320 US

Attn:

Attn: Accounts Payable

Customer PO	Reference	Sales Person	Terms
	U DESK	MARY JO WARNER	50% DEPOSIT, BALANCE NET 30

Line	Item	Description	Qty	Unit Price	Extended
15	DESIGN	DESIGN SERVICES PER MIDEAL OPEN OFFICE CONTRACT	1.00	85.96	85.96
16	LABOR	RECEIVE, DELIVER, & INSTALL PER MIDEAL OPEN OFFICE DURING REGULAR BUSINESS HOURS	1.00	593.75	593.75

Subtotal 2,853.23
Total Tax 130.41
Total Amount - USD 2,983.64

This Quote Expires on March 27, 2026

PRICING SUBJECT TO CHANGE AT ANY TIME DUE TO TARIFFS.

Deposit Required 1,491.82

Remit To:
 ISCG
 612 N. Main St.
 Royal Oak, MI 48067

Print Name

Title

Signature

Date



ISCG
 612 N. Main St.
 Royal Oak, MI 48067
 Phone: (248)399-1600
 Fax: (248)399-1601
 www.iscginc.com

QUOTE
2493.001
Project 2493
 Date Printed: Mar 27, 2026

Sold To: 16195-00
 CITY KEEGO HARBOR
 2025 BEECHMONT ST
 KEEGO HARBOR, MI 48320 US

Bill To: 16195-00
 CITY KEEGO HARBOR
 2025 BEECHMONT ST
 KEEGO HARBOR, MI 48320 US

Install Location: 16195-00
 CITY KEEGO HARBOR
 2025 BEECHMONT ST
 KEEGO HARBOR, MI 48320 US

Attn: Accounts Payable

Customer PO	Reference	Sales Person	Terms
	U DESK	MARY JO WARNER	50% DEPOSIT, BALANCE NET 30

Terms and Conditions

1. This Proposal is not a binding order unless signed by an authorized representative of the Buyer and accepted by a Manager at INTERIOR SYSTEMS CONTRACT GROUP INC. ("ISCG").
2. If requested by ISCG, the Buyer agrees to provide reasonable financial information necessary to approve credit. ISCG reserves the right to modify the terms of this Proposal, including deposit requirement, based on the information obtained.
3. The Buyer warrants that any financial information provided to ISCG is true and correct.
4. Product purchased on this Proposal is not cancelable or returnable.
5. All imposed tariffs assessed after order placement, and applicable sales and use taxes will be added at the time of invoicing and are the responsibility of the Buyer.
6. The Buyer agrees to ISCG's NET 30 payment terms. Payment in full is required on all delivered product. Payment for incorrect, or damaged product, may be withheld until issue is resolved or product replacement is delivered. Should Buyer be unable to accept delivery when product is available, Buyer agrees to be invoiced and ISCG will warehouse product for 30 days at no charge.
7. In the event of construction delays, or other causes not within ISCG's control, force postponement of the delivery and/or installation beyond 30 days, the products will be stored until installation can take place. The products will be considered accepted by the Buyer for purposes of invoicing and payment. The Buyer agrees to pay any reasonable storage charges incurred.
8. In the case of partial deliveries, the Buyer will accept invoice for all products delivered.
9. Delivery and installation will be made during normal business hours utilizing non-union labor. Buyer agrees to pay any additional charges resulting from overtime work, and/or union labor, performed at the Buyer's request.
10. Interest will be charged at the higher of 18% per annum, or the maximum rate permitted by law, on all past due amounts.
11. Buyer grants ISCG a security interest in the products described in this Proposal until full payment has been received. Buyer agrees to keep product free and clear of all claims and liens until ISCG has been paid in full.
12. ISCG is authorized to file a UCC-1 to further protect its security interest in any unpaid products.
13. Buyer understands and agrees that ISCG is not responsible for a manufacturer's inability to meet their estimated or expected ship dates. There is no offset, or other price reduction, due to a manufacturer delay.
14. Buyer must provide a free and clear job site during the installation. Elevator service and adequate facilities for offloading, staging,



ISCG
 612 N. Main St.
 Royal Oak, MI 48067
 Phone: (248)399-1600
 Fax: (248)399-1601
 www.iscginc.com

QUOTE
2493.001
Project 2493
 Date Printed: Mar 27, 2026

Sold To: 16195-00
 CITY KEEGO HARBOR
 2025 BEECHMONT ST
 KEEGO HARBOR, MI 48320 US

Bill To: 16195-00
 CITY KEEGO HARBOR
 2025 BEECHMONT ST
 KEEGO HARBOR, MI 48320 US

Install Location: 16195-00
 CITY KEEGO HARBOR
 2025 BEECHMONT ST
 KEEGO HARBOR, MI 48320 US

Attn:

Attn: Accounts Payable

Customer PO	Reference	Sales Person	Terms
	U DESK	MARY JO WARNER	50% DEPOSIT, BALANCE NET 30

moving, and handling of products must also be provided by the Buyer and without charge to ISCG. The Buyer is responsible for securing all necessary building permits.

15. Buyer is responsible for any damage to, or loss of, products after delivery. Until ISCG has been paid in full, Buyer shall maintain a policy of fire, and extended coverage insurance, on the full value of all products with loss payable to ISCG.
16. ISCG assigns all rights derived from the manufacturer's warranties to Buyer to the extent such rights are assignable. There are no other warranties, or extended warranties, provided as part of this Proposal.
17. Any controversy or claim arising out of, or relating to, this Proposal and Terms and/or Conditions, or any breach thereof, shall be settled in accordance with the Rules of the American Arbitration Association and judgment upon the award may be entered in any court.
18. Buyer agrees to pay ISCG's attorney's fee and all other costs incurred in the enforcement of these Terms and Conditions.
19. The use of VISA, MasterCard or American Express for deposits and/or invoice payments, above \$2,000, will be assessed an additional fee equal to 2.0% of the amount charged.
20. The Proposal and Terms and Conditions represent the entire Agreement between Buyer and ISCG and may not be changed without ISCG Management's written authorization.



To: City Council

Date: April 16, 2026

Subject: TIFA Expenditure- Canal Fountains

BACKGROUND

TIFA has recommended the purchase of 4 new floating fountain heads for the Brock Street canal, not to exceed \$900 from the TIFA budget.

RECOMMENDATION

Resolution to approve (or deny) the TIFA expenditure to purchase 4 new floating fountain heads for the Brock Street canal, not to exceed \$900 from the TIFA budget.



- Ask Rufus
- Does it come with a pump?
 - Can it be used in saltwater?
 - Is it easy to install?
 - Why you might like this
 - Compare with similar
 - Ask something else

EasyPro ACF3N Aqua Float Floating Fountain Head with Narrow Umbrella Nozzle / 2" Female Thread Inlet Connection / 24" Diameter Float with Decorative Cover

Visit the EasyPro Pond Products Store
4.7 ★★★★★ (12) | Search this page

\$218⁴⁹

Buying multiple items? Go to multi-select

Style: Narrow Umbrella Nozzle

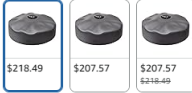

Material	High Density Polyethylene (HDPE)
Brand	EasyPro Pond Products
Exterior Finish	Matte
Inlet Connection Size	2 Inches
Inlet Connection Type	threaded
Outlet Connection Type	NPT
Number of Ports	2
Outlet Connection Size	2 Inches
Manufacturer	EasyPro Pond Products
UPC	812506017228

\$218⁴⁹

FREE delivery Monday, March 30. [Details](#)

Deliver to City - Keego Harbor 48320

In Stock

Qty: 1

Add to cart

Need more than 49 units?

Request for Quote

Secure transaction

Ships from and sold by CSJ&J Distribution.

Seller Credentials:

Business Hour Delivery
Registered Small Business, 889 Certification

Return policy: 30-day refund/replacement

Save this item

Add to List

Add to Auto Buy

Other sellers on Amazon

New (6) from \$207.57 & FREE Shipping

Product description



AquaFloat Floating Fountain Head with Nozzle

Using this fountain head you can build your own fountain by simply hooking a pump to it. Ideal for use with existing lawn sprinkling pump. Using this fountain head you can build your own fountain by simply hooking a pump to it. Ideal for use with existing lawn sprinkling pump.

The fountain head has a 24" diameter high density float and a decorative float cover. The spray nozzle threads on/off for easy cleaning. Inlet connection is 2" female threads.





Narrow Umbrella, Wide Umbrella and Rocket Nozzles



ACF1N



ACF2N



ACF3N



ACFNU



ACFRN



ACFWU

ACF3N AquaFloat Floating Fountain Head with Narrow Umbrella Nozzle

- Using this fountain head you can build your own fountain by simply hooking a pump to it
- Ideal for use with existing lawn sprinkling pump
- The fountain head has a 24" diameter high density float and a decorative float cover
- The spray nozzle threads on/off for easy cleaning
- Inlet connection is 2" female threads

Additional Information

- Weight: 14 lbs
- Float Diameter: 24 Inches
- Inlet Connection Size: 2 Inches
- Number of Ports: 2
- Style: Narrow Umbrella Nozzle
- Item Package Quantity: 1
- Inlet Connection Type: Female Threaded
- Model Number: ACF3N



To: City Council

Date: April 16, 2026

Subject: Graduation Banner and Flags Update

BACKGROUND

The sign-up form was released on April 13, 2026, with a submission deadline of May 4, 2026, at 5:00 p.m. The proposed installation date for the banner and flags is May 11, 2026, with removal scheduled for the week of June 1, 2026.

The banner will be installed on City property located at the intersection of Cass Lake Road and Orchard Lake Road. The Memorial Day Parade banner will also be displayed at this location.

RECOMMENDATION

Discussion



To: City Council
Date: April 16, 2026
Subject: City Facebook Page Update

BACKGROUND

On April 6, 2026, the City of Keego Harbor received a welcome email from CivicPlus confirming activation of the City's Social Media Archiving platform.

The email indicated:

- The City's archive has been activated
- Access credentials were sent via email
- An Implementation Specialist will be assigned to assist with setup

As part of implementation requirements, the City must adopt:

- A formal Social Media Policy
 - Standardized language for official social media platforms
 - Social Media Disclaimer- one way communication
 - Page is not monitored for emergencies

The City is currently in the process of finalizing these requirements to proceed with full implementation with the city attorney.

RECOMMENDATION



To: City Council
Date: April 16, 2026
Subject: Marine Patrol/ 4th of July Coverage

BACKGROUND

The City's current Marine Patrol contract is in effect through 2027. The existing agreement provides coverage 250 hours for \$23,322.50. Additional patrol services are anticipated for the July 4th holiday weekend. Accordingly, the FY 2026–2027 budget will reflect a total allocation of **\$35,000** for Marine Patrol services to accommodate both standard and supplemental coverage.

Additional marine patrol coverage is being considered:

	2025	2026	2027*
Marine Deputy with Boat	\$49.64	\$54.15	\$59.08
Marine Deputy with Boat Overtime Rate	\$64.30	\$70.15	\$76.54
Marine Deputy without Boat	\$35.88	\$39.14	\$42.70
Marine Deputy without Boat Overtime Rate	\$50.54	\$55.14	\$60.16

July 4th falls on a Saturday this year. The City is requesting authorization to provide supplemental coverage for the holiday weekend, including the following dates: Hourly Rated Deputy II

- Friday, July 3, 2026 = \$89.97 x 2
- Saturday, July 4, 2026 = \$179.94 x 2
- Sunday, July 5, 2026 = \$89.97 x 2

The Sheriff's Deputies to be assigned to Municipality under the Agreement to which this Schedule is attached will be Marine Deputies with a rank or classification of "PTNE", Part Time, Non-Eligible (for Benefits.)

The Hourly Rates upon which Municipality's payment obligation shall be determined are as follows:

RECOMMENDATION

Resolution to approve or deny the supplemental Marine Patrol coverage for the July 4th, 2026, holiday weekend (July 3–5, 2026), consistent with the existing contractual rate structure, in an amount not to exceed \$6,000.00., or 50 hours. Further, the City Council authorizes the City Manager to execute any necessary letters of agreement and/or amendments with Oakland County to secure the required marine patrol services, subject to the not-to-exceed amount established.

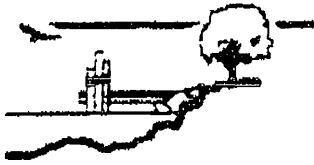

"Heart of the Lakes"

City of Keego Harbor

2025 Beechmont

Keego Harbor, Michigan 48320

DRAFT

Sheriff Michael Bouchard
Oakland County Sheriff's Office
1200 N. Telegraph Road
Pontiac, MI 48341

Re: Request for Supplemental Road Patrol Coverage – July 3–5, 2025

Dear Sheriff Bouchard,

The City of Keego Harbor is requesting to contract for supplemental law enforcement coverage over the upcoming holiday weekend of **July 3, 4, and 5, 2025**.

This request is made in anticipation of a larger-than-normal influx of visitors to Keego Harbor accessing the Cass Lake sandbar during the holiday period. The City seeks to ensure public safety, maintain orderly traffic flow, and support enforcement of local ordinances during this time.

The City requests addition road patrol supplemental staffing under the following parameters:

- Not to exceed **\$6,000 or 50 total hours**, whichever occurs first, for the duration of the contract period.
- **July 3, 2025:** Two (2) deputies from 1:00 p.m. to 7:00 p.m.
- **July 4–5, 2025:** Two (2) deputies per day, with specific hours to be assigned based on operational needs.

Additionally, this request authorizes the Oakland County Sheriff's Office to enforce applicable City of Keego Harbor ordinances during the period of supplemental staffing.

The Keego Harbor City Council has authorized the City Manager, Tammy Neeb, to enter into a contract with the County/Sheriff's Office consistent with the parameters outlined above.

We appreciate the continued partnership with the Oakland County Sheriff's Office in supporting the safety and well-being of our community and visitors.

Sincerely,

Tammy Neeb
City Manager



To: City Council

Date: April 16, 2026

Subject: Zoning Ordinance 4.05: Parking and Storage of Recreational Vehicles on vacant residentially zoned lots

BACKGROUND

- **Sec. 4.05. - Parking and storage of recreational vehicles on vacant residentially zoned lots.**

Not more than two (2) recreational vehicles, as defined in Section 2.00, Definitions, may be parked or stored on a vacant, separate lot of record than the principal structure subject to the following conditions:

(a) All recreational vehicles shall be currently registered and licensed to a current resident of Keego Harbor and/or the current property owner of record.

(b) The following recreational vehicles parked, or stored outdoors may not exceed:

(1) Travel trailer, thirty-five (35) feet or less in length.

(2) Camper trailer (pop-up), shall be stored in a collapsed position to a height not more than six (6) feet.

(3) Pick-up camper, thirty-two (32) feet or less in length.

(4) Watercraft, thirty-five (35) feet or less in length, but not to exceed twelve (12) feet in height, either mounted on a boat trailer or unmounted; also boat trailer without boat mounted.

(5) Motor home, forty (40) feet or less in length.

(c) Storage of recreational vehicles shall be in the rear one-third ($\frac{1}{3}$) of the lot, but, not closer than five (5) feet to a side or rear property line. Recreational vehicles may be stored within the clear vision triangle of a waterfront lot between September 15 and May 15.

(d) Recreational vehicles which are parked or stored shall be in good repair. Open storage of partially or disassembled component parts is prohibited. The vehicles must be capable of being moved from place to place.

(e) Recreational vehicles shall not be used for living, lodging or housekeeping purposes.

(f) Recreational vehicles parked or stored shall not be connected to electricity, water, gas, or sanitary sewer facilities.

(g) The owner of a recreational vehicle shall not park or store such a recreational vehicle in such a manner as to create a dangerous or unsafe condition on the lot where parked or stored. Parking or storage in such a fashion that the recreational vehicle, whether loaded or not, may readily tip or roll, shall be considered a dangerous and unsafe condition.

(h) The ground underneath the stored recreational vehicles must be surfaced and maintained to avoid muddy conditions and an unkempt appearance. It can be surfaced with natural ground cover, gravel, or crushed stone.

(i) Landscaping located at the rear and sides of the storage area shall comply with requirements in Section 15.23(d)(6) so as to create an evergreen or landscaped screen.

(j) For the purposes of this section, two (2) personal watercraft, snowmobiles, all-terrain vehicles, or motorcycles stored on a single trailer shall be counted as one (1) recreational vehicle.

(Ord. 338, 2/19/1998; 8/19/2021)

RECOMMENDATION

Motion to recommend the Planning Commission to review Zoning Ordinance Section 4.05 for possible changes and direction.